

**TECHNICAL MANUAL**

**TRANSPORTABILITY GUIDANCE**

**SMALL EMPLACEMENT EXCAVATOR (SEE)  
(NSN 2420-01-160-2754)**

**HIGH MOBILITY ENTRENCHER (HME)  
(NSN 2420-01-228-8610)**

**HIGH MOBILITY MATERIAL HANDLER (HMMH)  
(NSN 2420-01-205-8636)**

**Approved for public release; distribution is unlimited**



**TRANSPORTABILITY GUIDANCE**  
**SMALL EMPLACEMENT EXCAVATOR**  
**(NSN 2420-01-160-2754)**  
**HIGH MOBILITY ENTRENCHER (HME)**  
**(NSN 2420-01-228-8610)**  
**HIGH MOBILITY MATERIAL HANDLER (HMMH)**  
**(NSN 2420-01-205-8636)**

|         |  | Paragraph | Page |
|---------|--|-----------|------|
| CHAPTER | I. INTRODUCTION  |           |      |
|         | Purpose and Scope .....  | 1-1       | 1-1  |
|         | Reporting of Recommendations and Comments .....                          | 1-2       | 1-1  |
|         | Definitions of Warnings, Cautions, and Notes .....                       | 1-3       | 1-1  |
| CHAPTER | 2. TRANSPORTABILITY DATA   |           |      |
| SECTION | I. GENERAL   |           |      |
|         | Scope .....  | 2-1       | 2-1  |
|         | Description .....  | 2-2       | 2-1  |
|         | Transportability Drawings .....  | 2-3       | 2-1  |
|         | II. CHARACTERISTICS AND RELATED DATA                                     |           |      |
|         | General Transportability Characteristics .....                           | 2-4       | 2-7  |
|         | Reduced Configuration .....  | 2-5       | 2-6  |
|         | Unusual Characteristics .....  | 2-6       | 2-6  |
|         | Hazardous and Dangerous Characteristics .....                            | 2-7       | 2-6  |
| CHAPTER | 3. SAFETY  |           |      |
|         | General .....  | 3-1       | 3-1  |
|         | Specific Safety Requirements .....                                       | 3-2       | 3-1  |
| CHAPTER | 4. AIR TRANSPORTABILITY GUIDANCE   |           |      |
|         | Scope .....  | 4-1       | 4-1  |
|         | Maximum Use of Aircraft Capacity .....                                   | 4-2       | 4-1  |
|         | Applicability .....  | 4-3       | 4-1  |
|         | Safety .....   | 4-4       | 4-1  |
|         | Reparation of Equipment .....  | 4-5       | 4-1  |
|         | Transport by US Aircraft .....   | 4-6       | 4-1  |
|         | Transport by LVAD and LAPE .....   | 4-7       | 4-2  |
|         | Helicopter Transport .....   | 4-8       | 4-2  |
| CHAPTER | 5. HIGHWAY TRANSPORTABILITY GUIDANCE                                     |           |      |
| SECTION | I. GENERAL   |           |      |
|         | Scope .....  | 5-1       | 5-1  |
|         | Safety .....   | 5-2       | 5-1  |
|         | II. SELF-PROPELLED MOVEMENT  |           |      |
|         | General .....  | 5-3       | 5-1  |
|         | Preparation of the SEE, HME, and HMMH .....                              | 5-4       | 5-1  |
|         | III. TRANSPORT BY TRACTOR-TRAILER OR SEMITRAILER                         |           |      |
|         | General .....  | 5-5       | 5-1  |
|         | Transport on M345 Trailer .....  | 5-6       | 5-1  |
| CHAPTER | 6. MARINE AND TERMINAL TRANSPORTABILITY GUIDANCE                         |           |      |
| SECTION | I. GENERAL   |           |      |
|         | Scope .....  | 6-1       | 6-1  |
|         | Safety .....   | 6-2       | 6-1  |
|         | Water Shipment .....   | 6-3       | 6-1  |
|         | II. LOADING AND SECURING   |           |      |
|         | General Rules .....  | 6-4       | 6-1  |
|         | General Cargo and Barge-Type (LASH and SEABEE) Ships .....               | 6-5       | 6-1  |
|         | Roll-on/Roll-off (RORO), Seatrain, Landing, and Attack Cargo Ships ..... | 6-6       | 6-5  |

|  | Paragraph | Page |
|--|-----------|------|
| CHAPTER 7. RAIL TRANSPORTABILITY GUIDANCE                      |           |      |
| SECTION I. GENERAL   |           |      |
| Scope .....  | 7-1       | 7-1  |
| Maximum Use of Railcard .....                                  | 7-2       | 7-1  |
| II. TRANSPORT ON CONUS RAILWAYS                                |           |      |
| General .....  | 7-3       | 7-1  |
| Preparation .....  | 7-4       | 7-1  |
| Loading the SEE or Variants on a General-Purpose Flatcar ..... | 7-5       | 7-1  |
| Loading the SEE or Variants on Special-Purpose Flatcars .....  | 7-6       | 7-1  |
| III. TRANSPORT ON FOREIGN RAILWAYS                             |           |      |
| General .....  | 7-7       | 7-7  |
| Transport on Foreign-Service Flatcars .....                    | 7-8       | 7-7  |
| APPENDIX A. CONVERSION TABLES .....                            |           | A-1  |
| B. REFERENCES .....  |           | B-1  |

**LIST OF ILLUSTRATIONS**

| Figure |   | Page |
|--------|---|------|
| 2-1    | Small emplacement excavator (SEE) .....   | 2-2  |
| 2-2    | High mobility material handler (HMMH) .....   | 2-3  |
| 2-3    | Transportability drawing, left-side and rear views of the small emplacement excavator .....                               | 2-4  |
| 2-4    | Transportability drawing, left-side and rear views of the high mobility entrenched .....                                  | 2-5  |
| 2-5    | Transportability drawing, left-side and rear views of the high mobility material handler .....                            | 2-6  |
| 4-1    | Typical tiedown diagram for the SEE in US Air Force C-141 aircraft .....  | 4-3  |
| 4-2    | Typical tiedown diagram for the HME in US Air Force C-130 aircraft .....  | 4-4  |
| 4-3    | Typical tiedown diagram for the HMMH in US Air Force C-5 aircraft .....   | 4-5  |
| 4-4    | SEE being lifted with single-hook method by CH-47 helicopter .....  | 4-6  |
| 4-5    | SEE being lifted with dual-hook method by CH-47 helicopter .....  | 4-7  |
| 4-6    | SEE being lifted by CH-54 helicopter .....  | 4-8  |
| 4-7    | Front sling legs preparation on SEE (front view) .....  | 4-9  |
| 4-8    | Right rear sling leg preparation on SEE (rear view) .....   | 4-10 |
| 4-9    | Left rear sling leg preparation on SEE (rear view) .....  | 4-12 |
| 5-1    | Typical tiedown diagram for the SEE, HME, and HMMH on an M345 trailer (side view) .....                                   | 5-2  |
| 6-1    | Typical four-leg sling-lifting diagram for the SEE, HME, and HMMH with wire rope .....                                    | 6-2  |
| 6-2    | Typical blocking and tiedown of the SEE, HME, and HMMH in general-cargo and barge-type vessels .....                      | 6-3  |
| 6-3    | Typical loading of the SEE, HME, and HMMH on a LASH lighter with wire rope, cable clamps, turnbuckles, and blocking ..... | 6-6  |
| 6-4    | Typical tiedown of the SEE, HME, and HMMH on a RORO vessel .....  | 6-7  |
| 7-1    | Typical blocking and tiedown for the SEE and HME on a CONUS general-purpose flatcar (side view) .....                     | 7-2  |
| 7-2    | Typical blocking and tiedown for the SEE and HME on a CONUS general-purpose flatcar (rear view) .....                     | 7-3  |
| 7-3    | Typical blocking and tiedown detail diagram .....   | 7-4  |
| 7-4    | Typical tiedown for the SEE and variants on a CONUS conventional wood-deck, chain-tiedown flatcar (side view) .....       | 7-8  |
| 7-5    | Typical tiedown for the SEE and variants on a CONUS conventional wood-deck, chain-tiedown flatcar (rear view) .....       | 7-9  |

**LIST OF TABLES**

| Table |  | Page |
|-------|--|------|
| 5-1   | Bill of Materials for Blocking and Tiedown of the SEE, HME, and HMMH on the M345 Trailer (Fig 5-1)                               | 5-3  |
| 5-2   | Application of Materials for Blocking and Tiedown of the SEE, HME, and HMMH on the M345 Trailer (Fig 5-1) .....                  | 5-3  |
| 6-1   | Bill of Materials for Blocking and Tiedown of a Typical SEE, HME, and HMMH in a General-Cargo Vessel (Fig 6-2) .....             | 6-4  |
| 6-2   | Application of Materials for Blocking and Tiedown of a Typical SEE, HME, and HMMH in a General-Cargo Vessel (Fig 6-2) .....      | 6-4  |
| 7-1   | Bill of Materials for Blocking and Tiedown of the SEE and HME on a CONUS General-Purpose Flatcar (Figs 7-1 and 7-2) .....        | 7-5  |
| 7-2   | Application of Materials for Blocking and Tiedown of the SEE and HME on a CONUS General-Purpose Flatcar (Figs 7-1 and 7-2) ..... | 7-5  |
| 7-3   | Application of Chain Tiedowns for Securing the HMMH on HTTX or Similar Type of Flatcars (Figs 7-4 and 7-5) .....                 | 7-6  |

# CHAPTER 1

## INTRODUCTION

---

### 1-1. Purpose and Scope

This manual provides transportability guidance for logistical handling and movement of the small emplacement excavator (SEE), high mobility entrrencher (HME), and high mobility material handler (HMMH). It contains information considered appropriate for safe transport of the SEE and its variants. The information includes significant technical and physical characteristics, as well as safety considerations, required for worldwide movement by the various transport modes. Where considered necessary, metric equivalents appear in parentheses following the dimensions or other measurements. This manual is for transportation officers and other personnel responsible for moving the SEE, HME, and HMMH, or for providing transport services.

### 1-2. Reporting of Recommendations and Comments

Users of this manual are encouraged to submit comments and to recommend changes for its im-

provement. Comments and recommendations should be prepared on DA Form 2028 (Recommended Changes to DA Publications and Blank Forms) and forwarded to Commander, Military Traffic Management Command Transportation Engineering Agency, ATTN: MTTE-TRS, PO Box 6276, Newport News, VA 23606-0276. Electrically transmitted messages should be addressed to CDR MTMCTEA FT EUSTIS VA//MTTE-TRS//.

### 1-3. Definitions of Warnings, Cautions, and Notes

Throughout this manual, warnings, cautions, and notes emphasize important or critical guidance. They are used for the following conditions:

*a. Warning.* Instructions that, if not followed, could result in injury to or death of personnel.

*b. Caution.* Instructions that, if not strictly observed, could result in damage to or destruction of equipment.

*c. Note.* An operating procedure or condition that must be emphasized.

## CHAPTER 2 TRANSPORTABILITY DATA

---

### Section I. GENERAL

#### 2-1. Scope

This chapter provides transportability characteristics of the SEE, HME, and HMMH.

#### 2-2. Description

The SEE, HME, and HMMH are commercial items of construction equipment. The tractor portion of the equipment is a light truck chassis equipped with a diesel engine, multispeed range transmission, and offroad flotation tires. The tractor has a 45-mile-per-hour (72-km/h) highway convoy speed as well as a full drive rough-terrain capability.

*a.* The SEE tractor configuration consists of the basic tractor with a 3/4-cubic-yard-capacity front end loader and rear-mounted backhoe. The backhoe has a 7-cubic-foot-capacity bucket, as shown in figure 2-1.

*b.* The HME variant consists of the same basic tractor as the SEE, but with a dozer blade (85 inches wide and 32 inches high) on the front end and an entrencher on the rear. No photograph is available at this time.

*c.* The HMMH variant consists of the same basic tractor as the SEE, but with a 4,000-pound (1814-kg)-capacity forklift mounted to the front and a 6,000 pound (2722-kg)-capacity crane attached to the rear of the vehicle, as shown in figure 2-2.

#### 2-3. Transportability Drawings

Figures 2-3 through 2-5 are detailed side- and rear-view transportability drawings of the SEE, HME, and HMMH with dimensions, tiedown and lifting provisions, and load-rating capacities.



Figure 2-1. Small emplacement excavator (SEE).



*Figure 2-2. High mobility material handler (HMMH).*

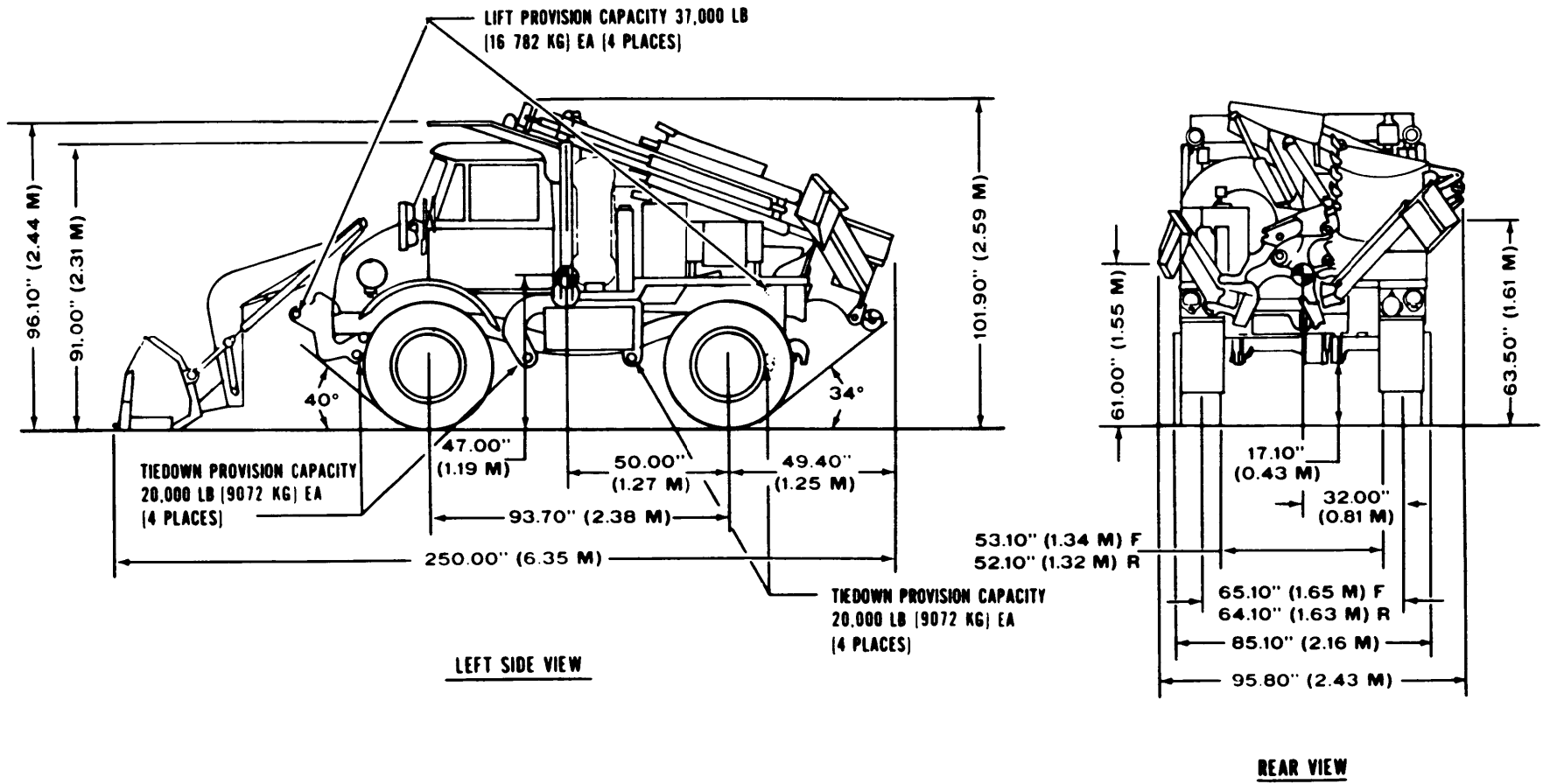

Figure 2-3. Transportability drawing, left-side and rear views of the small emplacement excavator.



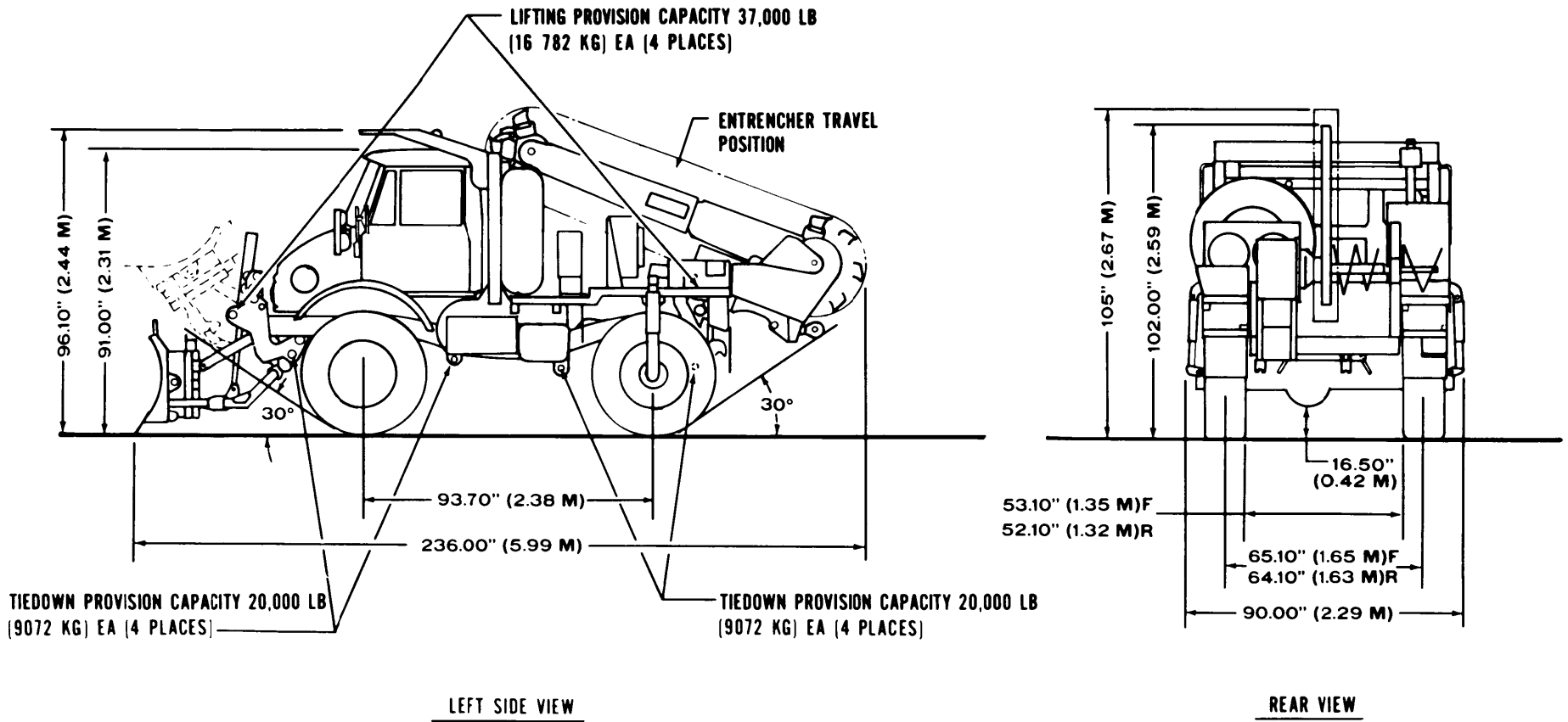

Figure 2-4. Transportability drawing, left-side and rear views of the high mobility entrencher.

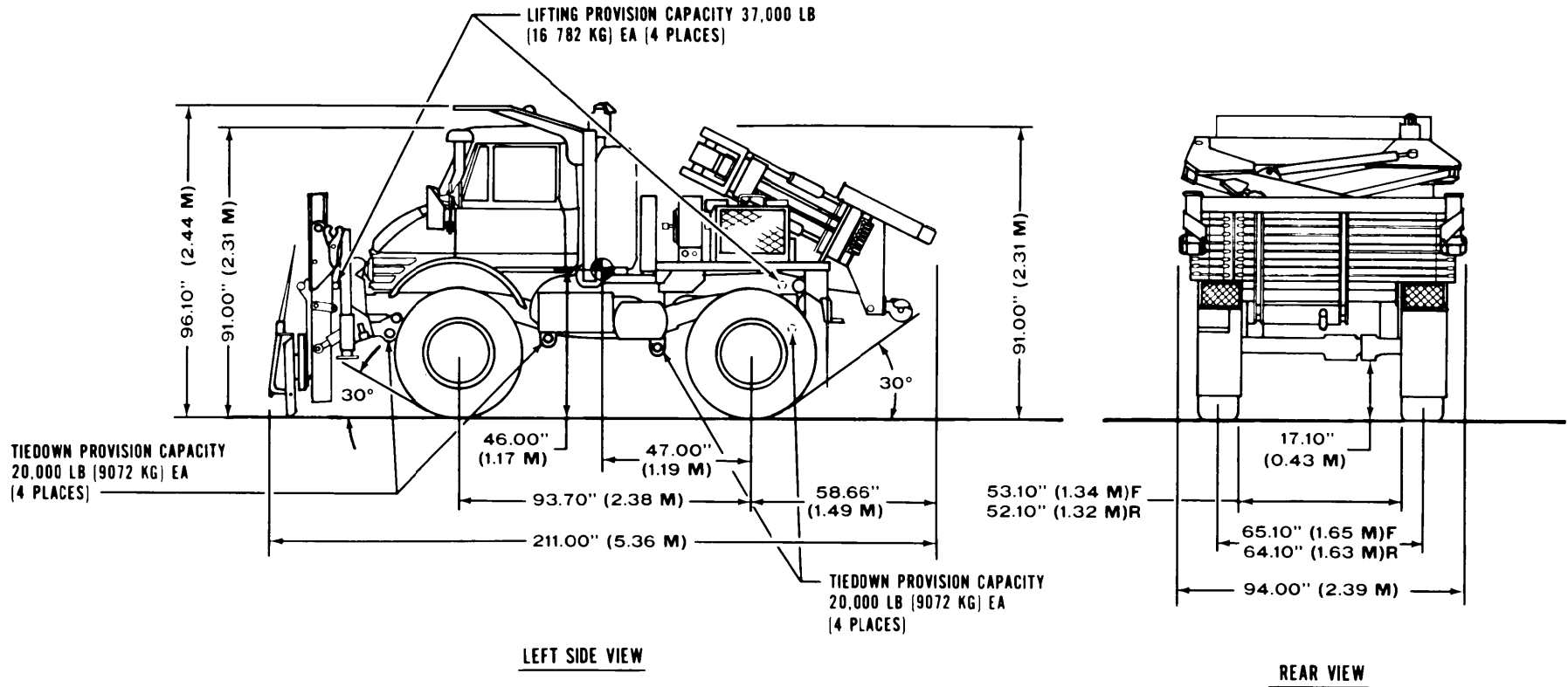

Figure 2-5. Transportability drawing, left-side and rear view of the High Mobility Material Handler.

Section II. CHARACTERISTICS AND RELATED DATA

2-4. General Transportability Characteristics

Data contained here apply to the model numbers or national stock numbers (NSN) shown. Changes in model numbers or NSN may affect the loadability of the item as related to the guidance in this manual.

a. Small Emplacement Excavator.

|   |   |
|---|---|
| National stock number .....               | 2420-01-160-2754                                |
| Line item number .....                    | T34437  |
| Length:                                   |   |
| Operational configuration (maximum) ..... | 340.2 in. (8.64 m)                              |
| Travel configuration .....                | 250.0 in. (6.35 m)                              |
| Width:                                    |   |
| Operational configuration (maximum) ..... | 95.8 in. (2.43 m)                               |
| Travel configuration .....                | 95.8 in. (2.43 m)                               |
| Height:                                   |   |
| Operational configuration (maximum) ..... | 96.1 in. (2.44m)                                |
| Travel configuration .....                | 101.9 in. (2.59 m)                              |
| Area:                                     |   |
| Operational configuration (maximum) ..... | 226.3 ft <sup>2</sup> (21.05 m <sup>2</sup> )   |
| Travel configuration .....                | 166.3 ft <sup>2</sup> (15.47 m <sup>2</sup> )   |
| Volume:                                   |   |
| Operational configuration (maximum) ..... | 1,720.7 ft <sup>3</sup> (48.73 m <sup>3</sup> ) |
| Travel configuration .....                | 1,412.3 ft <sup>3</sup> (39.99 m <sup>3</sup> ) |
| Weight:                                   |   |
| Front axle .....                          | 8,760 lb (3973 kg)                              |
| Rear axle .....                           | 7,160 lb (3248 kg)                              |
| Total weight .....                        | 15,920 lb (7221 kg)                             |
| Tires:                                    |   |
| Number/size .....                         | 4 ea 12.5 x 20                                  |
| Pressure:                                 |   |
| Front .....                               | 50 psi (344.40 kpa)                             |
| Rear .....                                | 45 psi (310.30 kpa)                             |
| Contact area:                             |   |
| Front .....                               | 89.9 in. <sup>2</sup> (0.06 m <sup>2</sup> )    |
| Rear .....                                | 95.5 in. <sup>2</sup> (0.06 m <sup>2</sup> )    |
| Speed/range:                              |   |
| Maximum speed .....                       | 45 mph (72.41 km/h)                             |
| Operational range .....                   | 10 hours  |
| Ground clearances-differential .....      | 17.1 in. (0.43 m)                               |

b. High Mobility Entrenched.

|                                    |   |
|------------------------------------|---|
| National stock number .....        | 2420-01-228-8610                                |
| Line item number .....             | T34437  |
| Length, travel configuration ..... | 236.0 in. (5.99 m)                              |
| Width, travel configuration .....  | 90.0 in. (2.29 m)                               |
| Height, travel configuration ..... | 105.0 in. (2.67 m)                              |
| Area, travel configuration .....   | 147.5 ft <sup>2</sup> (13.71 m <sup>2</sup> )   |
| Volume, travel configuration ..... | 1,290.6 ft <sup>3</sup> (36.55 m <sup>3</sup> ) |
| Weight:                            |   |
| Front axle .....                   | 7,830 lb (3551 kg)                              |
| Rear axle .....                    | 7,670 lb (3479 kg)                              |
| Total weight .....                 | 15,500 lb (7030 kg)                             |
| Tires:                             |   |
| Number/size .....                  | 4 ea 12.5 x 20                                  |
| Pressure:                          |   |
| Front .....                        | 55 psi (379.72 kpa)                             |
| Rear .....                         | 55 psi (379.72 kpa)                             |

|   |   |
|---|---|
| Contact area:                             |   |
| Front .....                               | 77.9 in. <sup>2</sup> (0.05 m <sup>2</sup> )    |
| Rear .....                                | 76.0 in. <sup>2</sup> (0.04 m <sup>2</sup> )    |
| Speed/range:                              |   |
| Maximum speed .....                       | 45 mph (72.41 km/h)                             |
| Operational range .....                   | 10 hours  |
| Ground clearances—differential .....      | 16.5 in. (0.42 m)                               |
| <i>c. High Mobility Material Handler.</i> |   |
| National stock number .....               | 2420-01-205-3636                                |
| Line item number .....                    | Z90450  |
| Length, travel configuration .....        | 211.0 in. (5.36 m)                              |
| Width, travel configuration .....         | 94.0 in. (2.39 m)                               |
| Height, travel configuration .....        | 96.1 in. (2.44 m)                               |
| Area, travel configuration .....          | 137.7 ft <sup>2</sup> (12.80 m <sup>2</sup> )   |
| Volume, travel configuration .....        | 1,130.0 ft <sup>3</sup> (30.89 m <sup>3</sup> ) |
| Weight:                                   |   |
| Front axle .....                          | 8,018 lb (3637 kg)                              |
| Rear axle .....                           | 7,632 lb (3462 kg)                              |
| Total weight .....                        | 15,650 lb (7099 kg)                             |
| Tires:                                    |   |
| Number/size .....                         | 4 ea 12.5 x 20                                  |
| Pressure:                                 |   |
| Front .....                               | 55 psi (379.72 kpa)                             |
| Rear .....                                | 55 psi (379.72 kpa)                             |
| Contact area:                             |   |
| Front .....                               | 79.5 in. <sup>2</sup> (0.05 m <sup>2</sup> )    |
| Rear .....                                | 76.1 in. <sup>2</sup> (0.04 m <sup>2</sup> )    |
| Speed/range:                              |   |
| Maximum speed .....                       | 45 mph (72.41 km/h)                             |
| Operational range .....                   | 10 hours  |
| Ground clearances—differential .....      | 17.1 in. (0.43m)                                |

**2-5. Reduced Configuration**

Lower cost shipping can be obtained by reducing each SEE, HME, and HMMH to its minimum dimensions for terminal handling and ocean transport. Both side mirrors are to be folded in, and the rear-mounted attachment is placed in the travel position.

**2-6. Unusual Characteristics**

These vehicles have no unusual characteristics that would require special attention be given to temperature, atmospheric pressure, or humidity

variations during their exposure to normal transportation environments.

**2-7. Hazardous and Dangerous Characteristics**

Under usual circumstances, the SEE, HME, and HMMH will not present any hazardous or dangerous characteristics during exposure to normal transportation environments.

**NOTE**

Those regulations and/or transportation procedures normally associated with vehicles containing diesel fuel apply.

## CHAPTER 3 SAFETY

---

### 3-1. General

General safety considerations and precautions for movement are as follows:

- a. Check each vehicle to ensure that all loose items are properly secured.
- b. When backing a vehicle, ensure that no personnel or obstacles are in danger of being hurt or damaged by the vehicle.

#### **WARNING**

Fire extinguishers must be readily available during all loading and unloading operations.

#### **WARNING**

When vehicle engine is operating, provide proper ventilation during loading and unloading operations. Prolonged inhalation of carbon monoxide fumes could be fatal.

### 3-2. Specific Safety Requirements

Appropriate chapters of this manual contain pertinent safety requirements by individual mode.

## CHAPTER 4

### AIR TRANSPORTABILITY GUIDANCE

#### 4-1. Scope

This chapter provides air transportability guidance for movement of the SEE, HME, and HMMH. It covers significant technical and physical characteristics and safety considerations. Also, it prescribes the materials required to prepare, load, and unload the SEE, HME, and HMMH when transported in the C-130, C-141, and C-5 US Air Force aircraft and the Boeing 747 Civil Reserve Air Fleet (CRAF) aircraft.

#### 4-2. Maximum Use of Aircraft Capacity

Additional cargo, including personnel within allowable load limits and restrictions prescribed by pertinent safety regulations, may be transported with these vehicles on US Air Force aircraft.

#### 4-3. Applicability

*a. US Air Force Aircraft.* When prepared for loading as described in paragraph 4-5, the SEE, HME, and HMMH are transportable in C-130, C-141, and C-5 aircraft.

*b. Tiedown Devices.* The SEE, HME, and HMMH will be tied down according to section IV of applicable procedures in TO 1C-XXX-9.

*c. Loadmaster.* The loadmaster will ensure that the loaded equipment is secured according to restraint criteria outlined in TO 1C-XXX-9.

#### NOTE

Air Force aircraft loads in this manual are illustrated to a minimum restraint of 3 g forward, 1.5 g aft, 1.5 g lateral and 2 g vertical. (Reference 1C-XXX-9 and MIL-STD-1791.)

#### 4-4. Safety

In addition to safety precautions contained in chapter 3, the following precautions apply for the SEE, HME, and HMMH:

*a.* Ensure that the fuel tanks are not less than one-fourth or more than three-fourths full.

*b.* Check each vehicle carefully to ensure that all loose items are properly secured.

*c.* Check each vehicle to ensure there are no fluid leaks.

*d.* Check all tiedown provisions and attached structural members for any damage.

*e.* Check tire pressure to ensure tires are at recommended highway pressure.

*f.* Check batteries to ensure they are protected against short circuits and secured so that leakage of acid cannot occur (reference TM 38-250, para 8-47a). Also, check the fuel tanks and hydraulic systems to ensure they comply with TM 38-250.

#### WARNING

Fire extinguishers must be readily available during all loading and unloading.

#### WARNING

Provide proper ventilation during loading. Prolonged inhalation of exhaust fumes could be fatal.

#### WARNING

Do not allow the vehicle to exceed 3 miles per hour (walking speed) inside the aircraft or on the loading ramps.

#### 4-5. Preparation of Equipment

*a.* Fold both mirrors and secure them with rope to the roll over protection structure (ROPS).

*b.* Secure rear attachments with 1/2-inch wire rope (safety cable) and two clips, when shipped in the travel position. Install wire rope taut (not tight) around the ROPS (or tiedown provision as directed) and rear attachment to restrain the attachment in case the mechanical lock is not engaged or fails.

#### 4-6. Transport by US Aircraft

*a.* The SEE, when shipped in C-130 and C-141 aircraft, will have the backhoe attachment in the operational configuration. The SEE should be backed into the C-130 and C-141 aircraft using two qualified operators. One driver operates the tractor and the other operates the backhoe, adjusting height during loading and unloading operations. Each SEE requires two stacks of parking shoring (2 x 6 inches x 4 feet, two per stack) between the front end loader and the aircraft floor. Also, place two stacks of shoring (2 x 6 inches x 4 feet, two per stack) under lowered bucket and aircraft floor.

*b.* The HME and HMMH, when shipped in C-130 and C-141 aircraft, must be in the travel configuration.

(1) *HME.* Install 1/2-inch wire rope (safety cable) through ROPS and over entrenched attachment, forming a loop. Secure the loop by pulling and installing the wire rope taut (not tight) with two 1/2-inch clips. Each HME requires two stacks

of parking shoring (2 x 6 inches x 4 feet, two per stack) between the front dozer blade and the aircraft floor.

(2) *HMMH*. Install 1/2-inch wire rope (safety cable) around top crane arm and through left center tiedown provision on chassis, forming a loop. Secure the loop by pulling the wire rope taut (not tight) and installing two 1/2-inch clips. Repeat same procedure for right side, except loop wire rope through right provision on chassis. Each *HMMH* requires two stacks of parking shoring (2 x 6 inches x 5 feet, two per stack) between the front forklift tines and the aircraft floor. Also the rear outriggers are to be secured with 1/2-inch wire rope (safety cable) looped around each outrigger and secured with two 1/2-inch clips.

c. The C-5 aircraft can transport the SEE, HME, and *HMMH* in the travel configurations.

(1) *SEE*. Install 1/2-inch wire rope (safety cable) taut (not tight) around the ROPS and the backhoe attachment and secure with two 1/2-inch clips. Also, install on right outrigger a 1/2-inch wire rope (safety cable) taut (not tight) through the bucket tiedown provisional and around outriggers. Repeat procedures for left outrigger. Each *SEE* requires two stacks of parking shoring (2 x 6 inches x 4 feet, two per stack) between the front end loader and the aircraft floor.

(2) *HME and HMMH*. To transport the HME and *HMMH* in the C-5 aircraft, follow the same procedures in paragraph 4-6b.

d. The shoring is required to protect the aircraft floor and any downward motion of the front or rear implements on the aircraft floor.

e. All shoring material will be furnished by the shipper and installed as directed by the aircraft loadmaster.

f. The aircraft commander or his/her representative ensures that the vehicles are loaded/unloaded and properly secured in the aircraft according to the criteria in section IV of the appropriate technical order.

g. Typical tiedown diagrams (figs 4-1 through 4-3) are based on acceptable methods. They can be used as a guide for loading and securing the SEE, HME, and *HMMH* aboard aircraft and also for preparing a vehicle for air transport. The tiedowns are part of the aircraft equipment.

#### 4-7. Transport by LVAD and LAPE

The SEE is certified for low altitude parachute extraction (LAPE) from US Air Force C-130 aircraft and certified for low velocity airdrop (LVAD) from US Air Force C-130 and C-141 aircraft. Preparation and procedures for LAPE and LVAD

airdrops are described in FM 10-539 and TO 13C7-1-17.

#### 4-8. Helicopter Transport

The SEE is within the external lift capability of the CH-47D helicopter in either single-hook (fig 4-3) or dual-hook (fig 4-4) configuration at airspeeds of 100 knots. The load is also suitable for external transport by the CH-54 helicopter (fig 4-5) at airspeeds of 95 knots.

##### a. Materials.

- (1) Sling set (25,000-pound capacity) – one each.
- (2) Nylon cord, Type III-as required.
- (3) Cotton webbing—as required.
- (4) Tape, adhesive, pressure-sensitive, 2-inch roll—as required.
- (5) Felt, padding, sheet—four each (for cushioning material).

##### b. Preparation.

- (1) Ensure that the front end loader assembly travel locks at the ends of both front end loader boom cylinders are properly pinned in place.
- (2) Secure steering wheel, doors, and all loose equipment with cord and tape as necessary.
- (3) Fold side mirrors inboard and tie or tape as required.
- (4) Tape windshield wipers to windshield.
- (5) Securely tie and tape engine compartment hood.
- (6) Tie or tape the hydraulic lines and hoses close to the forward lifting provisions to prevent possible entanglement during hookup.

##### c. Rigging Procedures.

- (1) Place apex fitting on top of the falling object protection system (FOPS). Route the outer sling legs (1 and 2) to the front of the SEE and the inner sling legs (3 and 4) to the rear of the SEE.

#### NOTE

Sling legs 1 and 3 should be the same side of the load.

- (2) Loop the chain ends of sling legs 1 and 2 through the respective front lifting provisions, and insert link 3 into the grabhook. Wrap a felt sheet around the chain ends of the sling legs and secure with tape or nylon cord (fig 4-7).

- (3) Loop the chain end of sling leg 3 through the right rear lifting provision (closest to the backhoe bucket) and insert link 10 into the grabhook. Wrap a felt sheet (cushioning material) around the chain end of the sling leg and secure with tape or nylon cord. Tape or tie excess chain links (fig 4-8).

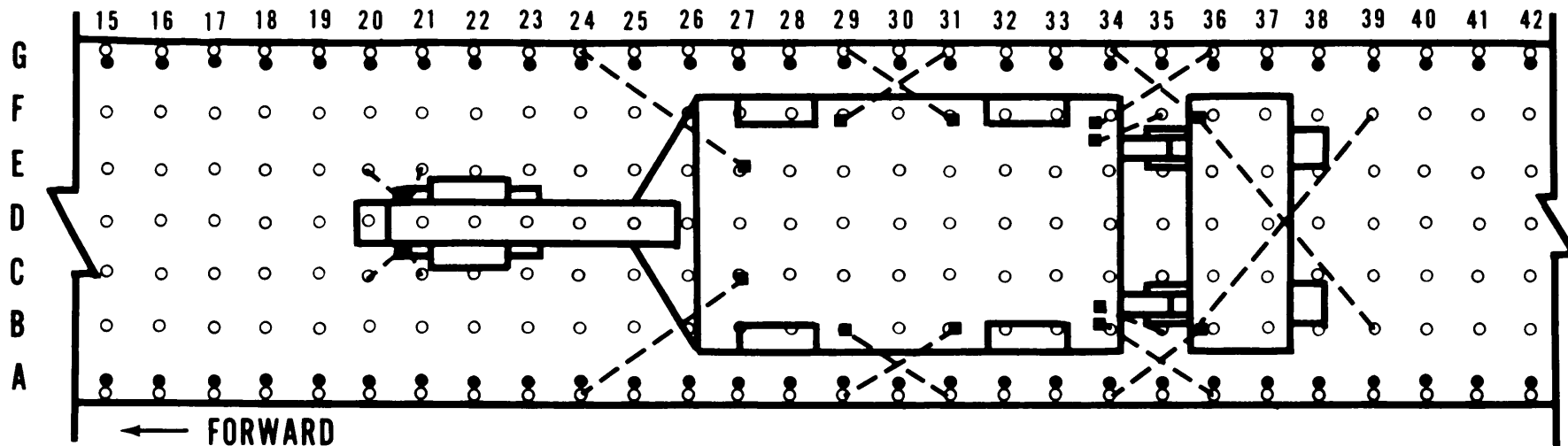

**LEGEND: C-141 AIRCRAFT**

- 10,000-POUND-CAPACITY TIEDOWN FITTING
- 25,000-POUND-CAPACITY TIEDOWN FITTING

**NOTE: FLOOR TIEDOWN FITTINGS ARE LOCATED IN ROWS A THROUGH G AND COLUMNS 1 THROUGH 56. THE RAMP HAS 6 ADDITIONAL COLUMNS. THIS IS A TYPICAL TIEDOWN PROCEDURE AND ONLY COLUMNS 15 THROUGH 42 ARE SHOWN. ITEM BEING SHIPPED CAN BE TIED DOWN AT ANY LOCATION APPROVED BY THE LOADMASTER.**

*Figure 4-1. Typical tiedown diagram for the SEE in US Air Force C-141 aircraft.*



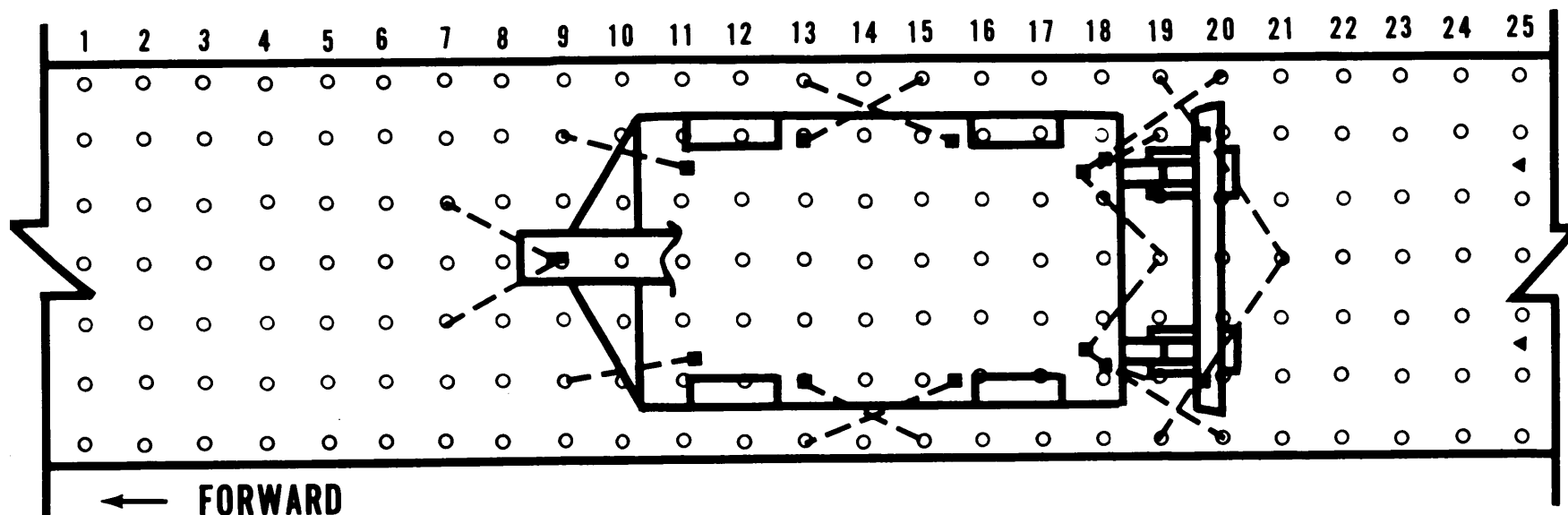

**LEGEND: C-130 AIRCRAFT**

- 10,000-POUND-CAPACITY TIEDOWN FITTING
- ▲ 25,000-POUND-CAPACITY TIEDOWN FITTING

**NOTE: FLOOR TIEDOWN FITTINGS ARE LOCATED IN ROWS A THROUGH F AND COLUMNS 1 THROUGH 25. THE RAMP HAS 5 ADDITIONAL COLUMNS. THIS IS A TYPICAL TIEDOWN PROCEDURE AND ONLY COLUMNS 1 THROUGH 25 ARE SHOWN. ITEM BEING SHIPPED CAN BE TIED DOWN AT ANY LOCATION APPROVED BY THE LOADMASTER.**

*Figure 4-2. Typical tiedown diagram for the HME in US Air Force C-130 aircraft.*

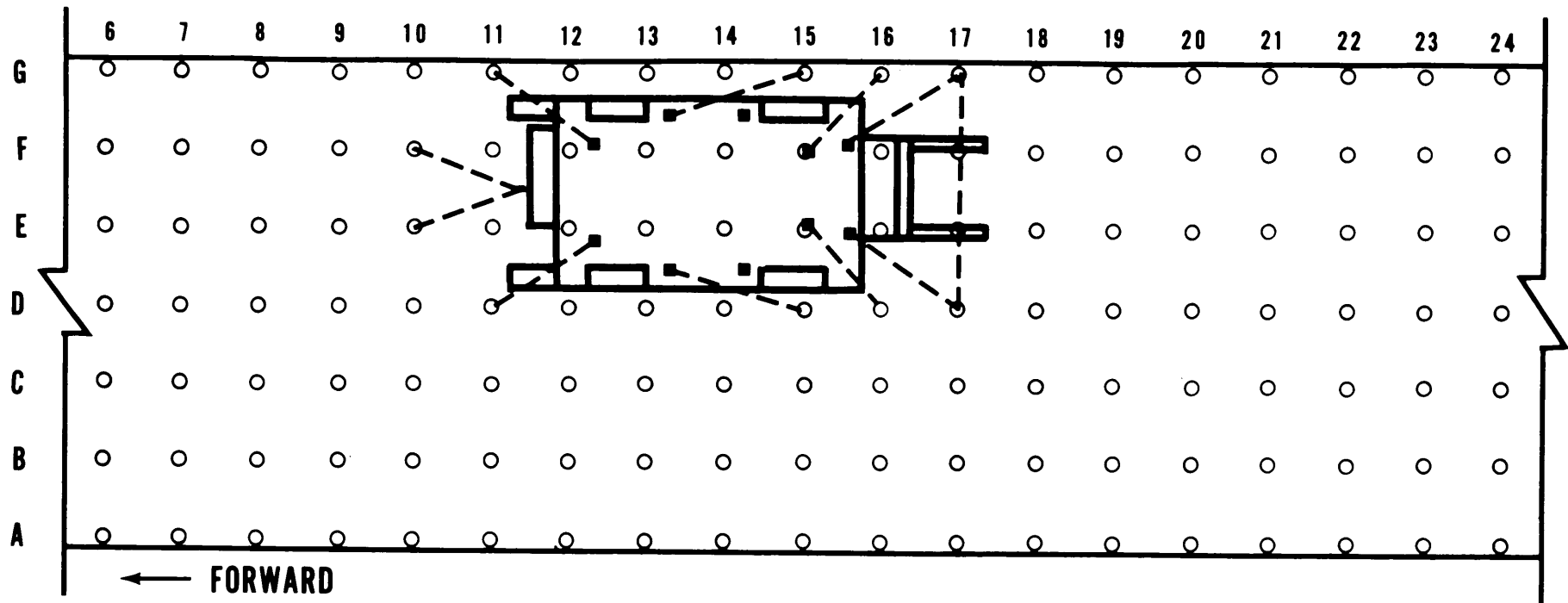

**LEGEND: C-5 AIRCRAFT**

○ ALL CARGO TIEDOWN FITTING RATINGS 25,000 LB EACH

**NOTE: FLOOR TIEDOWN FITTINGS ARE LOCATED IN ROWS A THROUGH G AND COLUMNS 1 THROUGH 38. ADDITIONAL COLUMNS OF TIEDOWNS ARE LOCATED ON THE RAMPS: FOUR ON THE FORWARD RAMP AND FIVE ON THE AFT RAMP. THIS IS A TYPICAL TIEDOWN PROCEDURE AND ONLY COLUMNS 6 THROUGH 24 ARE SHOWN. ITEM BEING SHIPPED CAN BE TIED DOWN AT ANY LOCATION APPROVED BY THE LOADMASTER.**

*Figure 4-3. Typical tiedown diagram for the HMMH in US Air Force C-5 aircraft.*

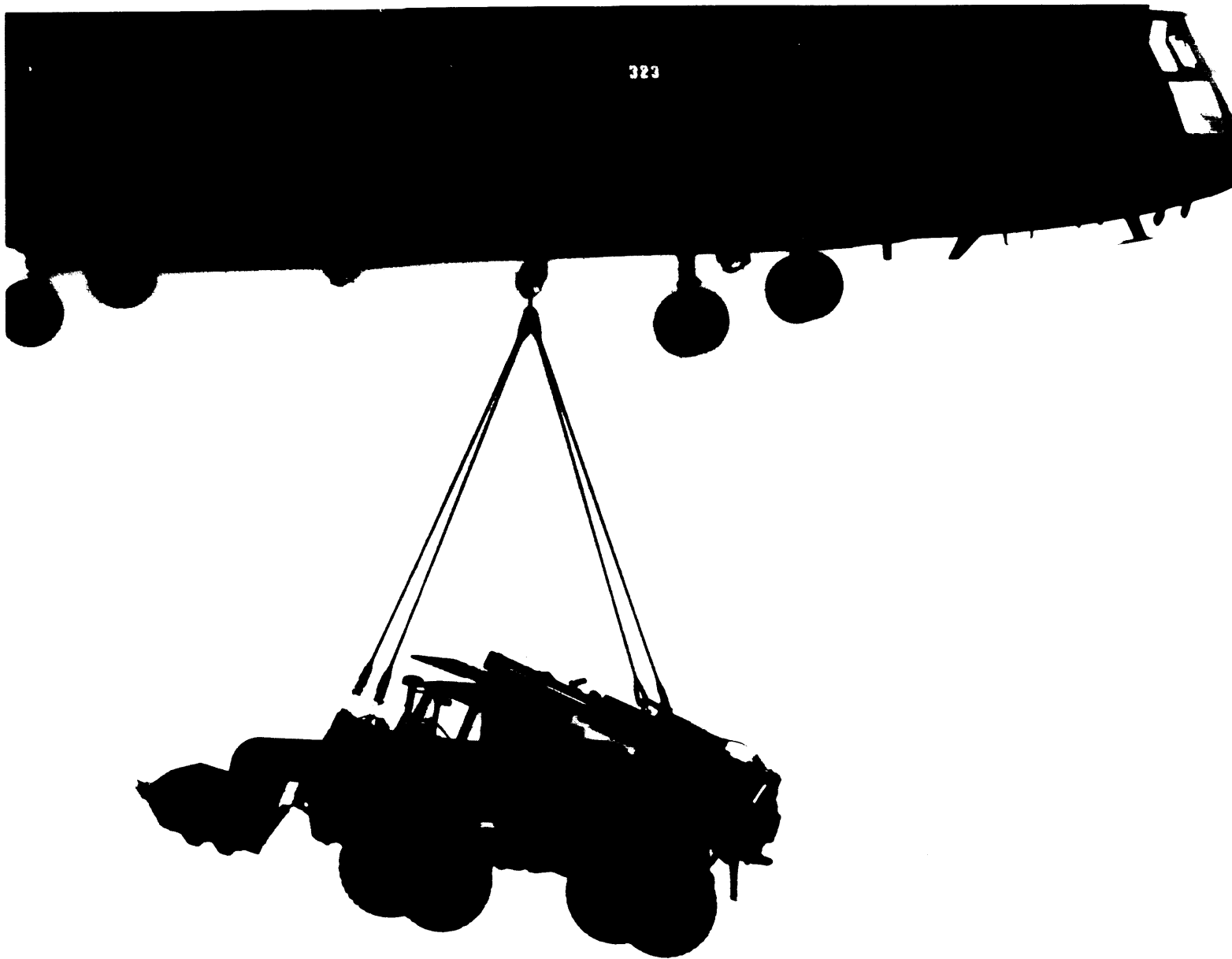
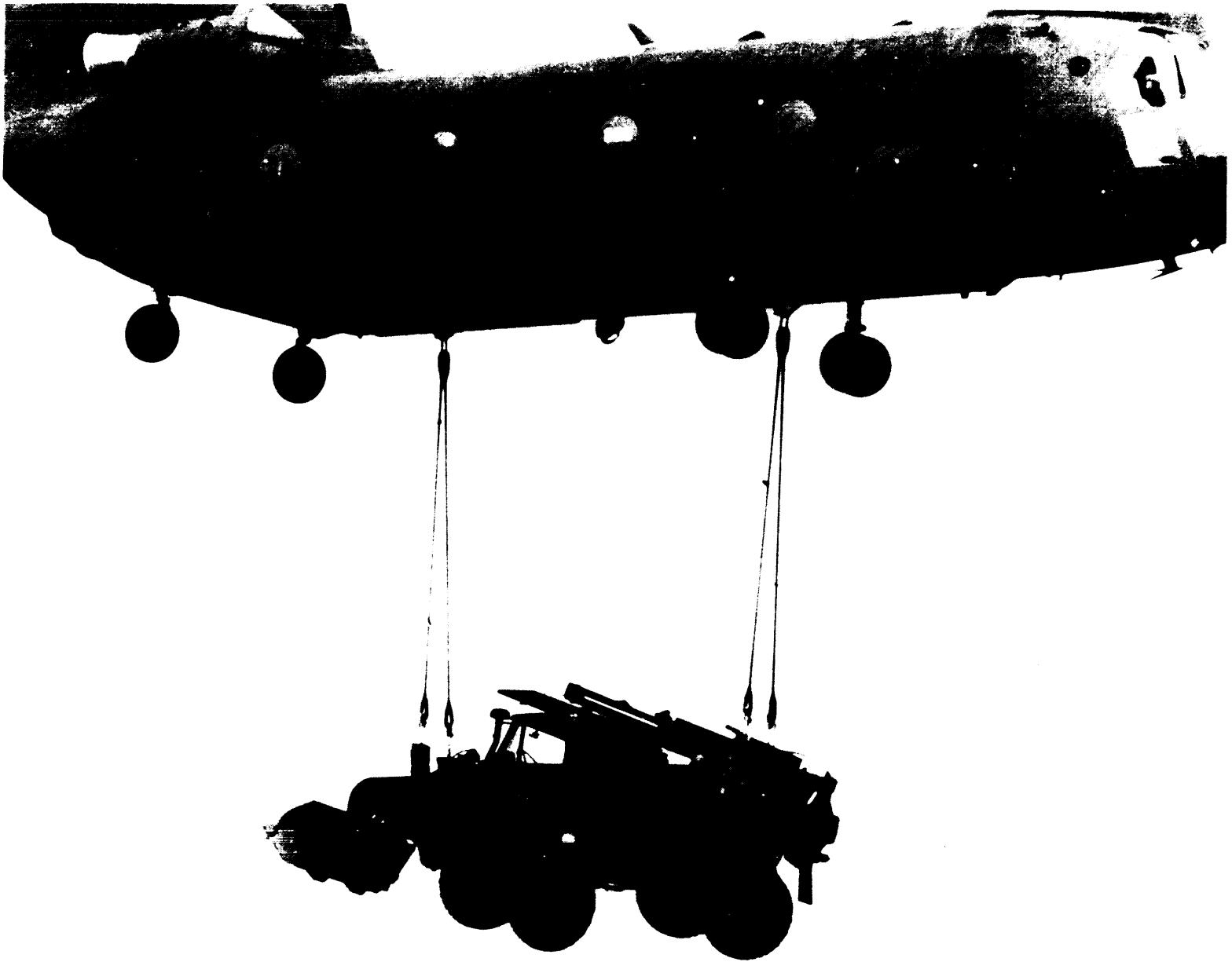

Figure 4-4. SEE being lifted with single hook method by CH-47 helicopter.



*Figure 4-5. SEE being lifted with dual hook method by CH-47 helicopter.*



*Figure 4-6. SEE being lifted by CH-54 helicopter.*

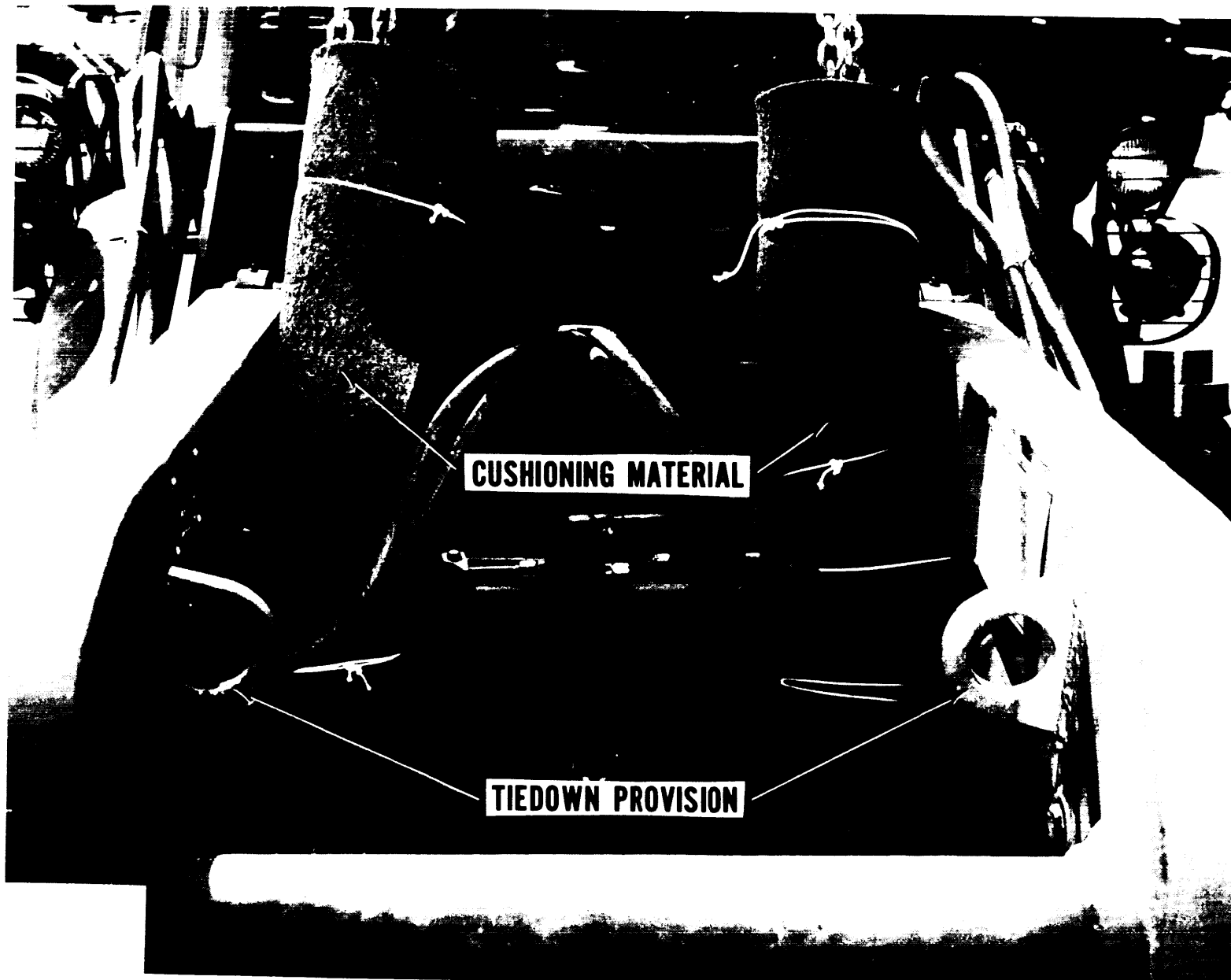

Figure 4-7. Front sling legs preparation on SEE.



Figure 4-8. Right rear sling leg preparation on SEE.

(4) Loop the chain end of sling leg 4 through the left rear lifting provision (closest to backhoe operator's seat), and insert link 5 into the grab-hook. Wrap a felt sheet (cushioning material) around the chain end of the sling leg and secure with tape or nylon cord (fig 4-9).

(5) Cluster and tie or tape (breakaway technique) all sling legs above the FOPS to prevent entanglement during hookup.

(6) Dual-hook procedures are identical except two apex fittings are used—one for sling legs 1 and 2 and one for sling legs 3 and 4.

*d. Hookup.*

(1) vehicle should fly with rear end forward.

(2) Hookup team sits or squats on FOPS, facing aft. The assistant hookup person discharges static electricity with the static probe. The hookup person places the apex fitting on the aircraft cargo hook. Both persons carefully dismount and remain beside the load as the helicopter removes slack from the sling legs. When a successful hookup is assumed, the hookup team briskly exits the area underneath the helicopter.

(3) Dual-hook procedures are similar except the hookup persons place two apex fittings on two different cargo hooks. Apex fitting 1 goes onto the forward cargo hook and apex fitting 2 goes onto the rearward cargo hook. Do not use the center aircraft hook.





Figure 4-9. Left rear sling leg preparation on SEE.

## CHAPTER 5 HIGHWAY TRANSPORTABILITY GUIDANCE

---

### Section I. GENERAL

#### 5-1. Scope

This chapter provides highway transportability guidance for movement of the SEE, HME, and HMMH. It covers significant technical and physical characteristics, as well as safety considerations. It also prescribes the materials and guidance required to prepare, load, and tie down these vehicles.

#### 5-2. Safety

In addition to safety precautions in chapter 3, movement within CONUS is subject to all safety

laws, rules, and regulations that apply to commercial carriers. In overseas areas, movements are governed by the theater and local regulations.

#### CAUTION

Do not allow the SEE, HME, and HMMH to exceed 3 miles per hour (walking speed) during loading and unloading operations.

#### CAUTION

Do not disconnect trailer from transporter during loading and unloading.

### Section II. SELF-PROPELLED MOVEMENT

#### 5-3. General

The SEE, HME, and HMMH are self-deployable throughout CONUS, Alaska, and Hawaii without permits. Also, they are transportable worldwide. However, they may need a permit for exceeding the length limits in 17 countries, height limits in 34 countries, weight limits in 4 countries, and width in 18 countries. Legal limitations for foreign countries are identified in the Limits of Motor Vehicle Sizes and Weights, International Road Federation, Geneva, Switzerland.

#### 5-4. Preparation of the SEE, HME, and HMMH

When transported under their own power, the SEE, HME, and HMMH must have the front and rear implements raised to the travel position and safety cable installed as described in paragraph 4-5b.

### Section III. TRANSPORT BY TRACTOR-TRAILER OR SEMITRAILER

#### 5-5. General

The SEE, HME, and HMMH can be transported over highways by tractor-trailer or tractor-semitrailer. All variants can be transported by both the M915A1/M345 and the M915A1/M269A1 tractor-trailer/semitrailer, and larger, combinations. Highway shipments may be made using either military or commercial lowbed semitrailers of adequate capacity and size. The tiedown procedures for transport on trailer or semitrailer will be similar to those described in paragraph 5-6.

Applications of tiedowns and blocking are listed in table 5-2.

*c. Loading.*

#### WARNING

At no time during loading and unloading operations should personnel, other than the guide and the driver of the SEE, HME, or HMMH, be on the trailer bed.

#### WARNING

Loading should not be conducted on side or lateral slopes exceeding 10 percent or with a tractor-to-trailer offset angle greater than 5°. Avoid loading on severe downgrades to prevent the payload from uncontrollable rolling or sliding forward or aft on trailer.

#### 5-6. Transport on M345 Trailer.

*a. General.* The SEE, HME, and HMMH are to be loaded on the M345 trailer as shown in figure 5-1.

*b. Material.* Adequate tiedown chains, binders, and materials for blocking are listed in table 5-1.

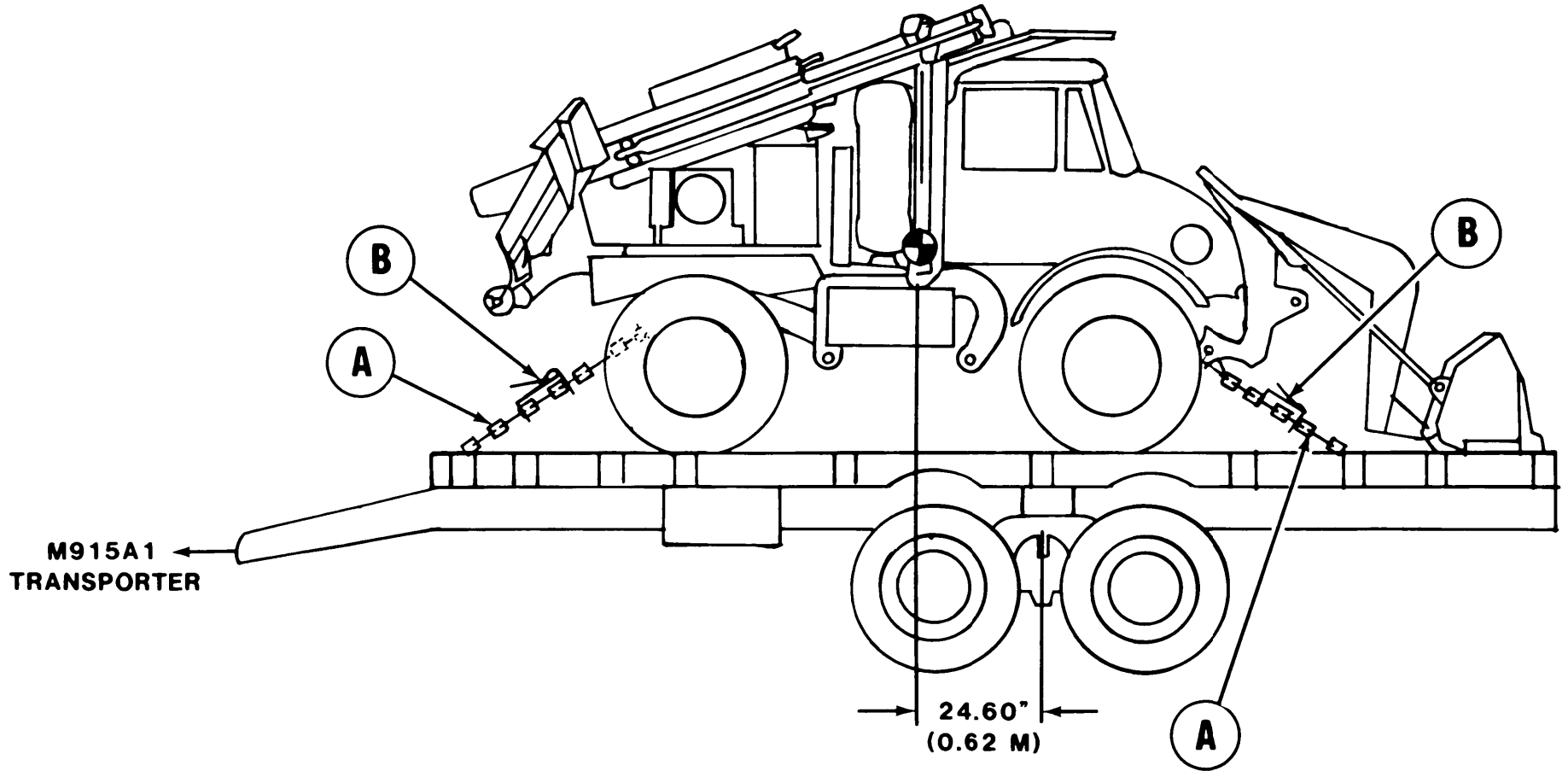

Figure 5-1. Typical tiedown diagram for the SEE, HME, and HMMH on an M345 trailer (side view).

**Table 5-1. Bill of Materials for Blocking and Tiedown of the SEE, HME, and HMMH on the M345 Trailer (Fig 5-1)**

| Item         | Description   | Approximate Quantity |
|--------------|---|----------------------|
| *Chains      | 120-inch-long x 1/2-inch-diameter, high-test chain (working load limit 9,200 pounds), type I, grade C, class 2; welded steel, Fed Spec RR-C-271; with two grabhooks equal to or better than the strength of the chain | 4                    |
| Load binders | Double-hook, heavy-duty, eccentric takeup with chain grabhooks for 1/4- to 1/2-inch chain, working load limit 9,200 pounds, type II, class 1, style C; Fed Spec GGG-B-325B  | 4                    |

\*1/2-inch wire rope with U-bolt clamps (4 ea) and thimbles (4 ea) may be substituted for 1/2-inch chain.

**Table 5-2. Application of Materials for Blocking and Tiedown of the SEE, HME, and HMMH on the M345 Trailer (Fig 5-1)**

| Item | No. Required | Application  |
|------|--------------|--|
| A    | 4            | <i>Chain.</i> Run one end of chain through tiedown provision and the other end through trailer tiedown ring. Secure both ends of chain to load binder (item B) and then secure the load binder. Wire-tie load binder handle in closed position. (Repeat procedure at all four tiedown provisions.) |
| B    | 4            | <i>Load binder.</i> Secure grabhooks to chains, and remove slack with eccentric takeup.  |

## CHAPTER 6 MARINE AND TERMINAL TRANSPORTABILITY GUIDANCE

---

### Section I. GENERAL

#### 6-1. Scope

This chapter provides marine and terminal transportability guidance for movement of the SEE, HME, and HMMH. It covers significant technical and physical characteristics, as well as safety considerations. Also it prescribes the materials required to prepare, lift, tie down, and discharge the SEE, HME, and HMMH.

#### 6-2. Safety

In addition to the safety precautions contained in chapter 3, the following areas should be noted as applicable:

- a. Fire extinguishers must be available during all loading and unloading operations.
- b. Vessel equipment and gear should be inspected for damage and wear before being used.
- c. Slings, chains, cables, and other items used in loading, discharge, and tiedown operations shall be inspected for condition and adequate capacity.

d. Personnel should be cautioned not to walk under vehicle being lifted.

e. Lifting provisions and connected structural members on each vehicle shall be inspected to ensure that they are complete and not damaged.

f. All lifts should have at least one tag line attached to a tiedown fitting to control the sway of the SEE, HME, and HMMH while suspended.

#### 6-3. Water Shipment

The vehicles can be transported by a large variety of inland-waterway carriers and lighters and by all seagoing cargo vessels.

##### NOTE

The methods described in this chapter for lifting and securing the SEE, HME, and HMMH are suggested procedures. Other methods of handling and stowing may be used provided they will ensure safe delivery without damage.

### Section II. LOADING AND SECURING

#### 6-4. General Rules

a. *Stowage.* When possible, the SEE, HME, and HMMH should receive the protection of below-deck stowage. The SEE, HME, and HMMH can be loaded as deck cargo provided the tractors have protective covering. In general, good stowage of the SEE, HME, and HMMH means they are placed as close together as practical, with minimum space between outer vehicles and sweatboards. Also, their brakes are set with brake lever wire-tied, and the transmission is placed in neutral.

b. *Lifting.* The SEE, HME, and HMMH have four lifting provisions each. Two are over both rear wheels and two are on the front frame. Typical four-leg lifting diagrams are shown in figure 6-1.

c. *Loading.* The SEE, HME, and HMMH will be loaded on seagoing cargo vessels in its travel configuration. They may be loaded in the travel configuration aboard landing craft, beach discharge lighters, and amphibious lighters under their own power or by a crane with a 10-ton capacity (minimum). They can also be driven or towed aboard roll-on/roll-off vessels or onto the decks of barges.

#### 6-5. General Cargo and Barge-Type (LASH and SEABEE) Ships

##### CAUTION

Vehicle fuel tanks must be drained and purged, and battery terminals must be disconnected and taped.

a. *Lighterage.* The SEE, HME, and HMMH are transportable on all Army lighterage vessels except the LARC V. Transporting the SEE, HME, and HMMH by lighterage to or from vessels requires blocking. Also, use tiedown restraints when transporting the tractors for extended distances or through rough water.

b. *Securing.* Requirements for securing the vehicles aboard general-cargo vessels are basically the same as for barge-type vessels. The wheels of the vehicles are blocked in front, in rear, and on both sides. Then the vehicles are lashed with wire rope or chains to bulkheads, stanchions, or padeyes. Figure 6-2 shows typical blocking and tiedown details, and table 6-1 lists the materials for blocking and tiedown. Application of materials is shown in table 6-2.

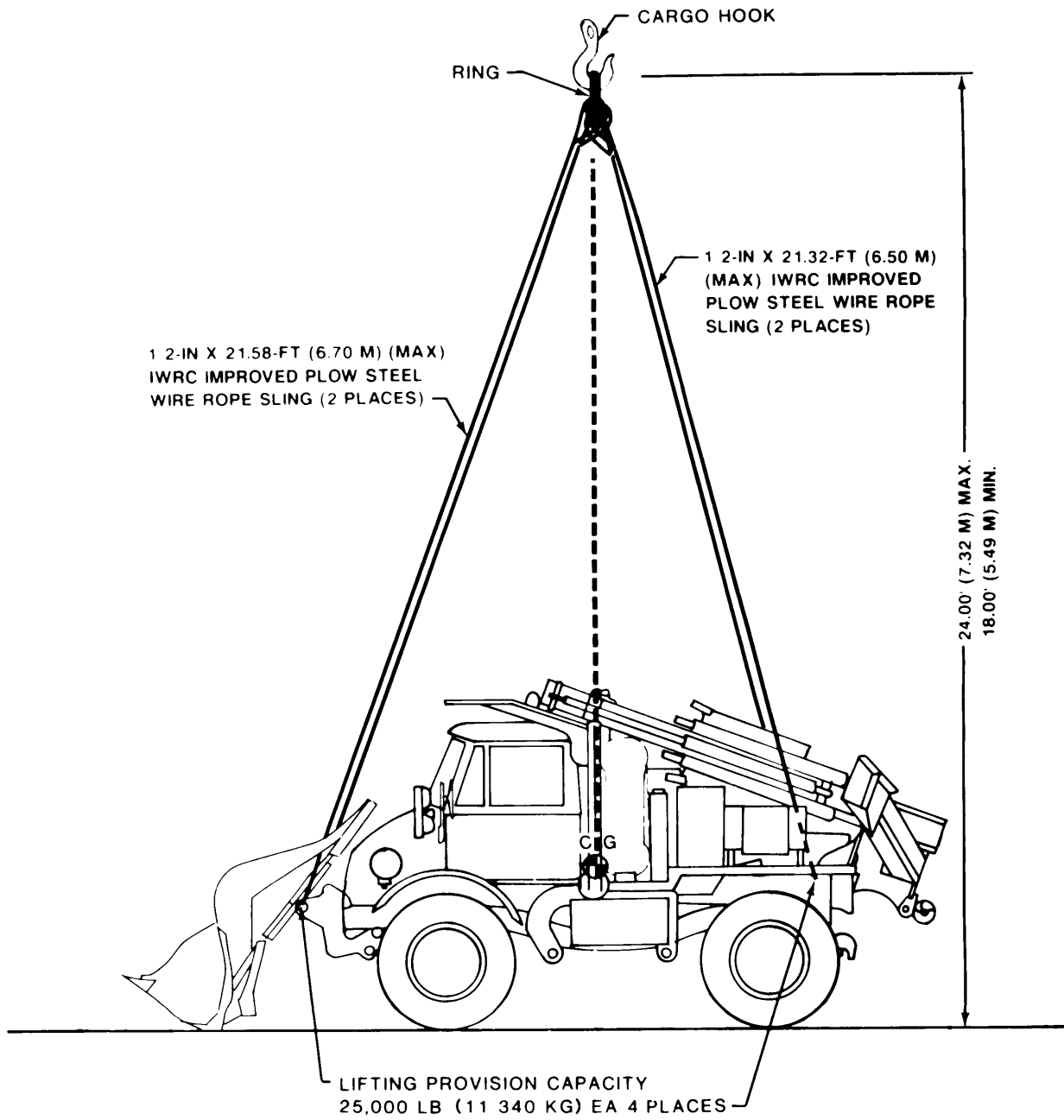

Figure 6-1. Typical four-leg sling-lifting diagram for the SEE, HME, HMMH with wire rope.

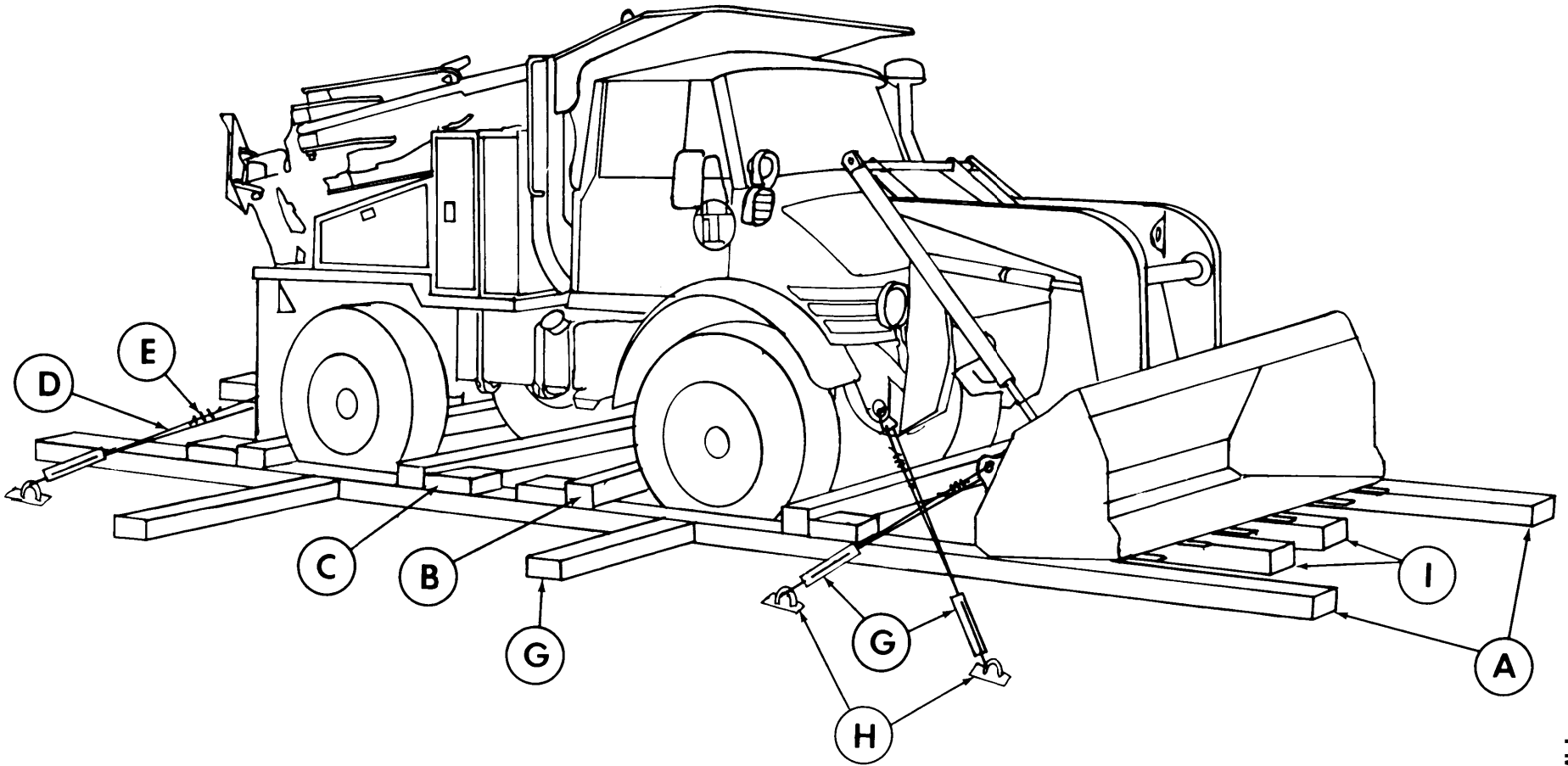

Figure 6-2. Typical blocking and tiedown of the SEE, HME, and HMMH in general-cargo and barge-type vessels.

**Table 6-1. Bill of Materials for Blocking and Tiedown of a Typical SEE, HME, and HMMH in General-Cargo Vessel (Fig 6-2)**

| Item        | Description   | Approximate Quantity             |
|-------------|---|----------------------------------|
| Turnbuckles | Eye-and-jaw type, 3/4-inch diameter x 10-inch takeup or equal   | 6                                |
| Lumber      | Douglas-fir, or comparable, straight-grain, free from material defects; Fed Spec MM-L-751H: 4- x 6-inch<br>6- x 8-inch<br>(Does not include lumber for side blocking) | 8 linear feet<br>101 linear feet |
| Nails       | Common, steel; flathead; bright or cement-coated; Fed Spec FF-N-105B: 40d   | 90                               |
| Wire rope   | 6 x 19, IWRC; improved plow steel; performed, regular-lay; table X, Fed Spec RR-W-410C: 1/2-inch  | 80 feet                          |
| Clamps      | Wire rope, U-bolt clips, saddled, single-grip, steel, Crosby heavy-duty, or equal; Fed Spec FF-C-450: 1/2-inch  | 21                               |

**Table 6-2. Application of Materials for Blocking and Tiedown of a Typical SEE, HME, and HMMH in General-Cargo Vessel (Fig 6-2)**

| Item | No. Required | Application  |
|------|--------------|--|
| A    | 2            | <i>Side blocking.</i> Each consists of 6- x 8- x 260-inch* lumber. Place one piece on each side of tractor against outside of tires.   |
| B    | 4            | <i>End blocking.</i> Each consists of 6- x 8- x 100-inch* lumber. Place on top of item A, against front and rear of front wheels and rear wheels. Toenail to item A with four 40d nails, two in the side and two in each end.  |
| C    | 8            | <i>Backup cleats.</i> Each consists of 4- x 6- x 12-inch lumber. Place one on top of each item A against item B. Toenail to item A with four 30d nails, one in each side and two in the ends.  |
| D    | 6            | <i>Wire rope.</i> Form a complete loop through each shackle and the eye of a turnbuckle. Overlap wire rope ends at least 24 inches.  |
| E    | 21           | <i>Clamps.</i> Place three on each wire rope at the overlapped area and space 3 inches apart, with a minimum of 6 inches from ends of wire rope. Evenly tighten clamps to a torque of 65 foot-pounds.  |
| F    | 4            | <i>Turnbuckles.</i> Attach jaw end to padeye in deck. Tighten as required.   |
| G    | as required  | <i>Bracing.</i> Consists of 6- x 8-inch lumber, cut-to-fit. Brace as required against adjacent vehicle blocking, cargo, or vessel bulkhead. Secure each end of each piece to adjacent blocking by toenailing with four 40d nails. Lumber and nails for this requirement are not included in table 6-1. |
| H    | 6            | <i>Padeye.</i> Six required on floor of vessel.  |
| I    | 2            | <i>Shoring.</i> Each consists of 6- x 8- x 36-inch lumber. Place under front bucket on both left and right side of center of bucket. Secure shoring to bucket with wire.   |

\*Approximate lengths may be cut-to-suit.



*c. Stowage in Barges.* Figure 6-3 shows the arrangement for stowing six SEES or variants in barge-type vessels. The vehicles should be loaded symmetrically in sequences about the centerline of the barge. They should be loaded in a manner to counterbalance variations in centers of gravity.

#### **6-6. Roll-On/Roll-Off (RORO), Seatrain, Landing, and Attack Cargo Ships**

##### **NOTE**

When the SEE, HME, and HMMH are loaded onto vessels that are adequately ventilated by power blowers, such as RORO vessels, the fuel need not be drained and batteries need not be disconnected.

*a. Loading.* The SEE, HME, and HMMH can be driven or towed aboard RORO vessels.

*b. Securing.* RORO, seatrain, landing, and attack cargo ships have patented lashing gear (Peck and Hale equipment is often used) and permanent fittings on their decks. Four Peck and Hale lashings, size 35M, should be used to tie down each SEE, HME, and HMMH; two lashings, crossed, from the forward tiedown points with shackles and two lashings, crossed, from the aft tiedown points with shackles to the "cloverleaf" deck sockets or bulkhead fitting. Blocking and bracing is not required with adequate patented lashing gear (fig 6-4). Use Peck and Hale lashing, type 4M or 35M; one lashing from front bucket (SEE) or dozer blade (HME) tiedown point and across the bucket or blade to the "cloverleaf" deck sockets or bulkhead. Lower forklift implement (HMMH) on shoring, secure with lashing across tines from deck sockets.

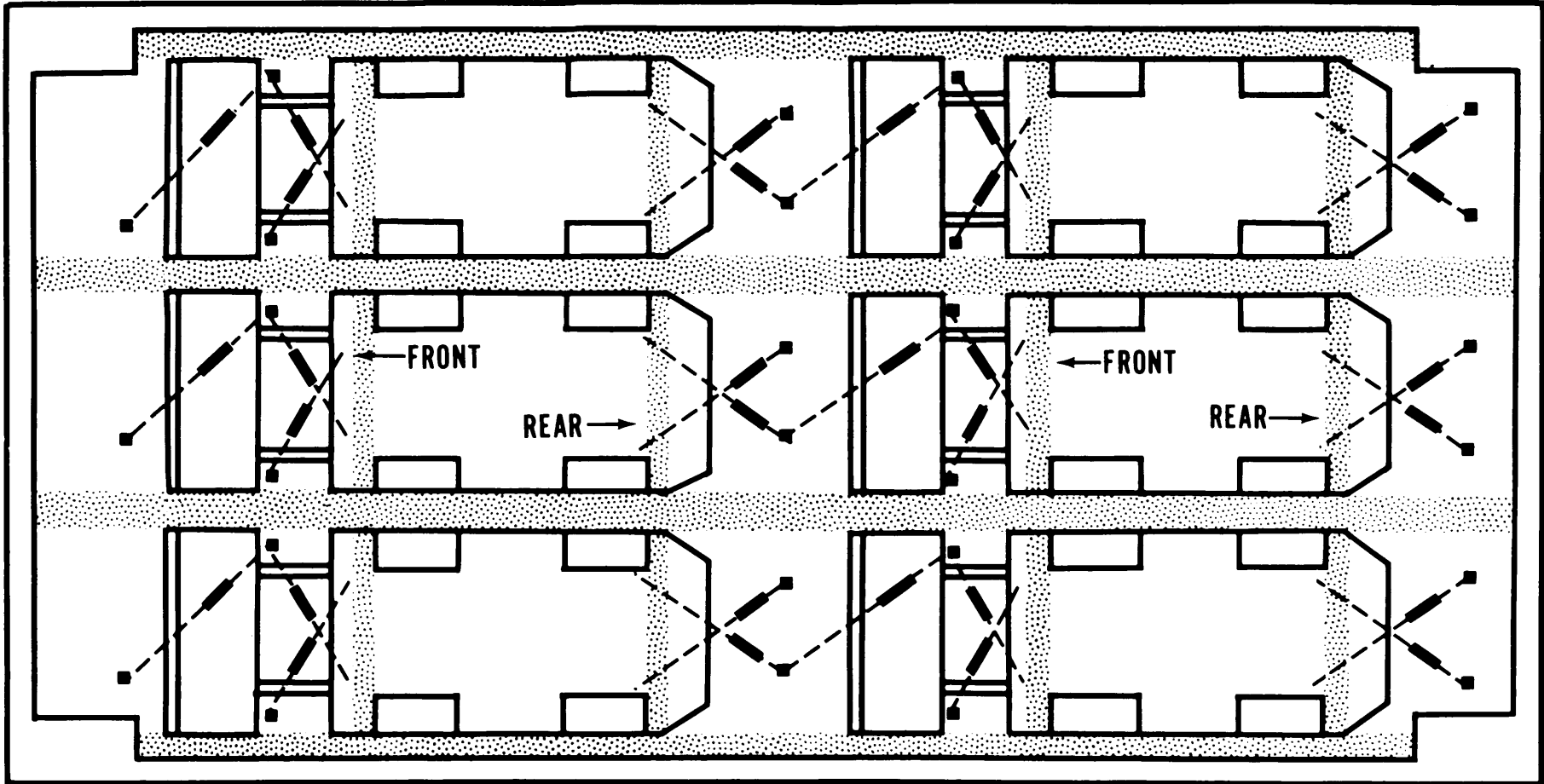

BLOCKED AND BRACED WITH 4' × 6' LUMBER,  
 LENGTH CUT-TO-SUIT AND FORCED FITTED. TIE  
 DOWN WITH 1/2" WIRE ROPE AND 1/2" CABLE  
 CLIPS AND TURNBUCKLES.

NOTE: REAR ATTACHMENTS (BACKHOE, TRENCHER  
 & CRANE) ARE TO BE PLACED IN THE TRAVEL POSITION.

Figure 6-3. Typical loading of the SEE, HME, and HMMH on a LASH lighter with wire rope, cable clamps, turnbuckles, and blocking.

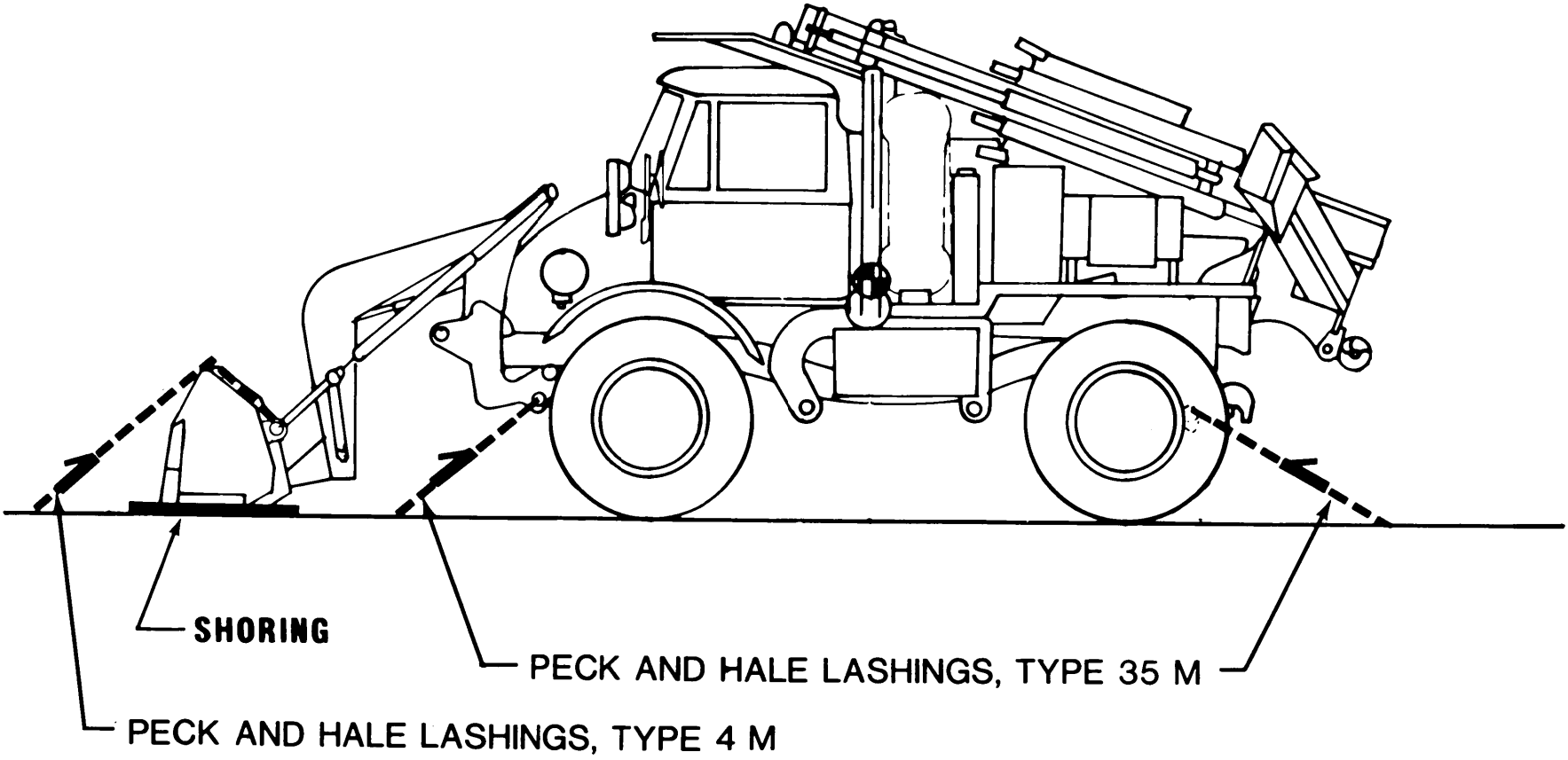

Figure 6-4. Typical tiedown of the SEE, HME, and HMMH on a RORO vessel.

## CHAPTER 7 RAIL TRANSPORTABILITY GUIDANCE

---

### Section I. GENERAL

#### 7-1. Scope

This chapter provides rail transportability guidance for movement of the SEE, HME, and HMMH. It covers technical and physical characteristics and safety considerations. It also prescribes the material and guidance required to prepare, load, and

tie down the SEE, HME, and HMMH on open-top flatcars.

#### 7-2. Maximum Use of Railcars

Additional cargo, as approved by the activity offering the SEE or variants for transport, may be transported with the SEE or variants.

### Section II. TRANSPORT ON CONUS RAILWAYS

#### 7-3. General

The transportability guidance contained in this section applies when the SEE or variants are transported on CONUS railways. Consideration is given to single and multiple movements on the types of flatcar normally used to move this vehicle. The SEE or variants can be transported on a 50-inch-high deck railcar without restriction throughout CONUS.

with 1/2-inch wire rope and two clamps, in their retracted position to prevent extension during transport. Tie felt padding around the hydraulic cylinders on the backhoe implement for protection against damage during rail shipment.

#### 7-4. Preparation.

*a.* The SEE will be in the travel configuration for rail transport. A 1/2-inch wire rope (safety cable) with two clamps will be installed taut (not tight) around the ROPS and the backhoe attachment for a safety device if the locking device fails. Outriggers are tied, with 1/2-inch wire rope and two clamps, in their retracted position to prevent extension during transport. Foam padding will be tied around the hydraulic cylinders on the backhoe attachment for protection against damage during rail shipment.

#### 7-5. Loading the SEE or Variants on a General-Purpose Flatcar

*a.* The SEE or variants may be placed in the tiedown position on a railcar by a crane (refer to para 6-4b for lifting instructions), or it may be driven or towed onto the railcar provided a suitable ramp or bridge is available.

#### CAUTION

Do not allow the SEE or variant to exceed 3 miles per hour (walking speed) during loading or unloading operations.

*b.* The HME will be in the travel configuration for rail transport. A 1/2-inch wire rope (safety cable) with two clamps will be installed taut (not tight) around the ROPS and entrenched implement for a safety device if the locking device fails.

*b.* Loads shown in figures 7-1 and 7-2 are based on a flatcar that is 9 feet 4 inches wide. Table 7-1 is a bill of materials and table 7-2 is the application of materials for securing the SEE or variants on general-purpose flatcars.

*c.* The HMMH will also be in the travel configuration for rail transport. Secure rear crane implement with a 1/2-inch wire rope (safety cable) looped around crane arm and through right side center tiedown provision on chassis for a safety device if the locking device fails. Repeat same procedure on left side. Also the outriggers are tied,

#### 7-6. Loading the SEE or Variants on Special-Purpose Flatcars

The loads shown in figures 7-4 and 7-5 are based on the use of CONUS conventional wood-deck chain-tiedown flatcars. These cars are equipped with special heavy-duty tiedown anchors and chain assemblies contained in a channel along each side of the car and on each side of the center sill. Table 7-3 presents application of chain tiedowns for securing the HMMH.

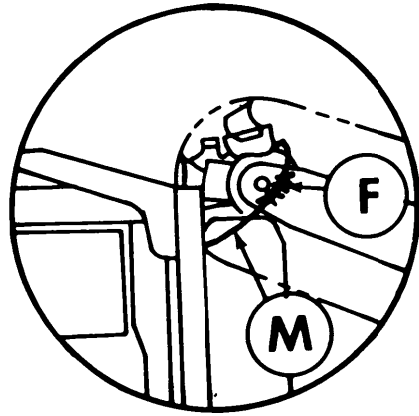

**HME DETAIL**

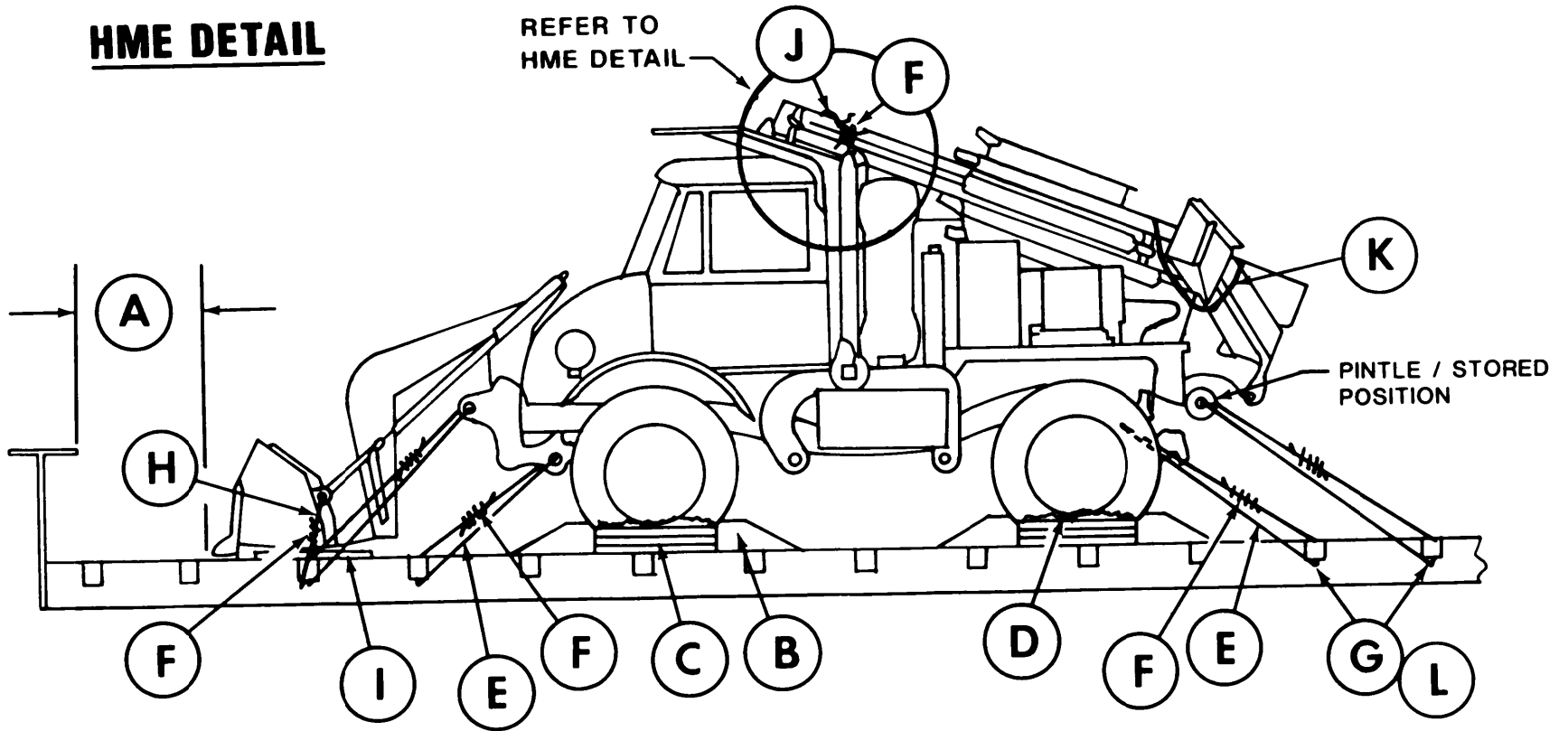

Figure 7-1. Typical blocking and tiedown for the SEE and HME on a CONUS general-purpose flatcar (side view).

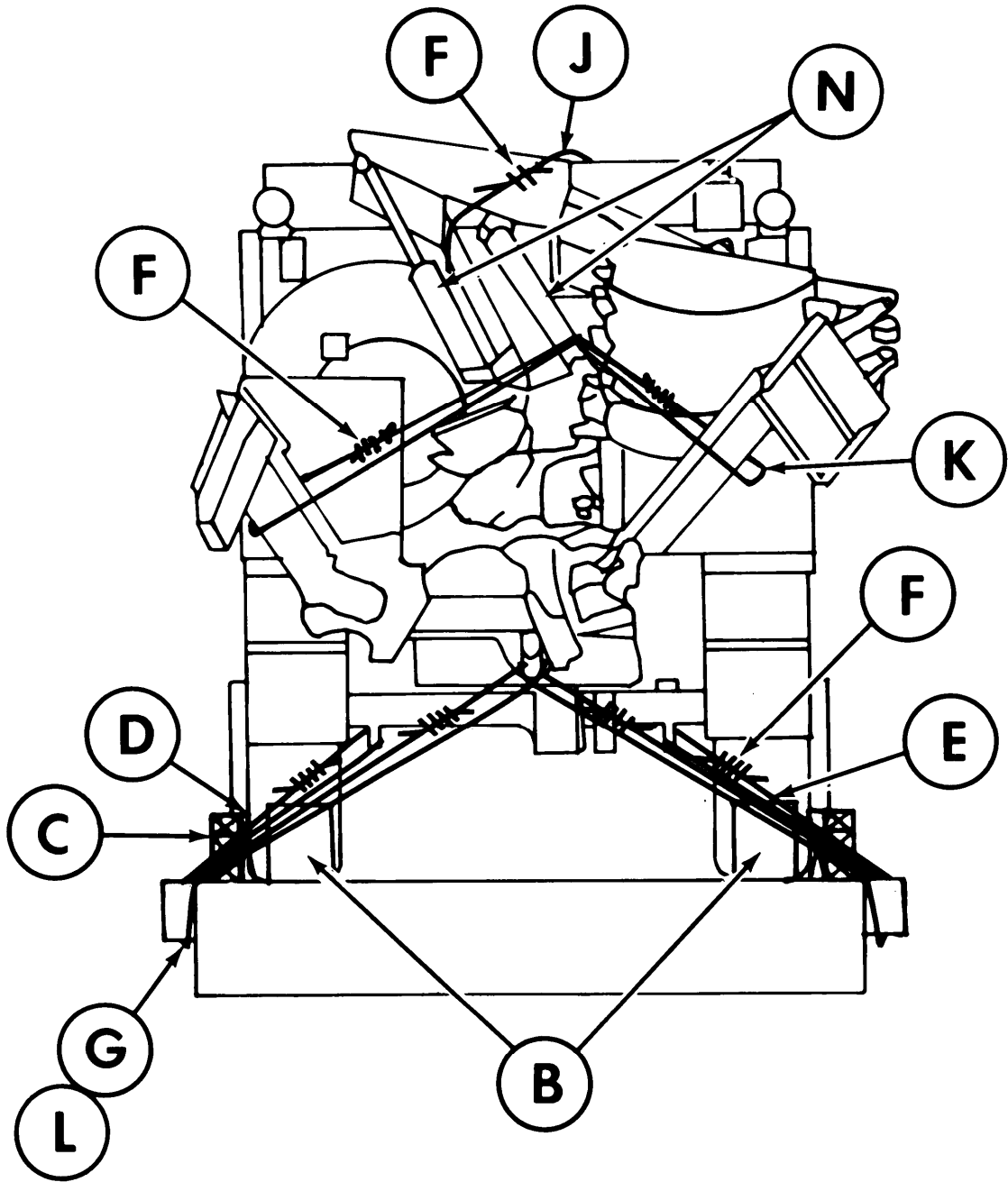

Figure 7-2. Typical blocking and tiedown for the SEE and HME on a CONUS general-purpose flatcar (rear view).

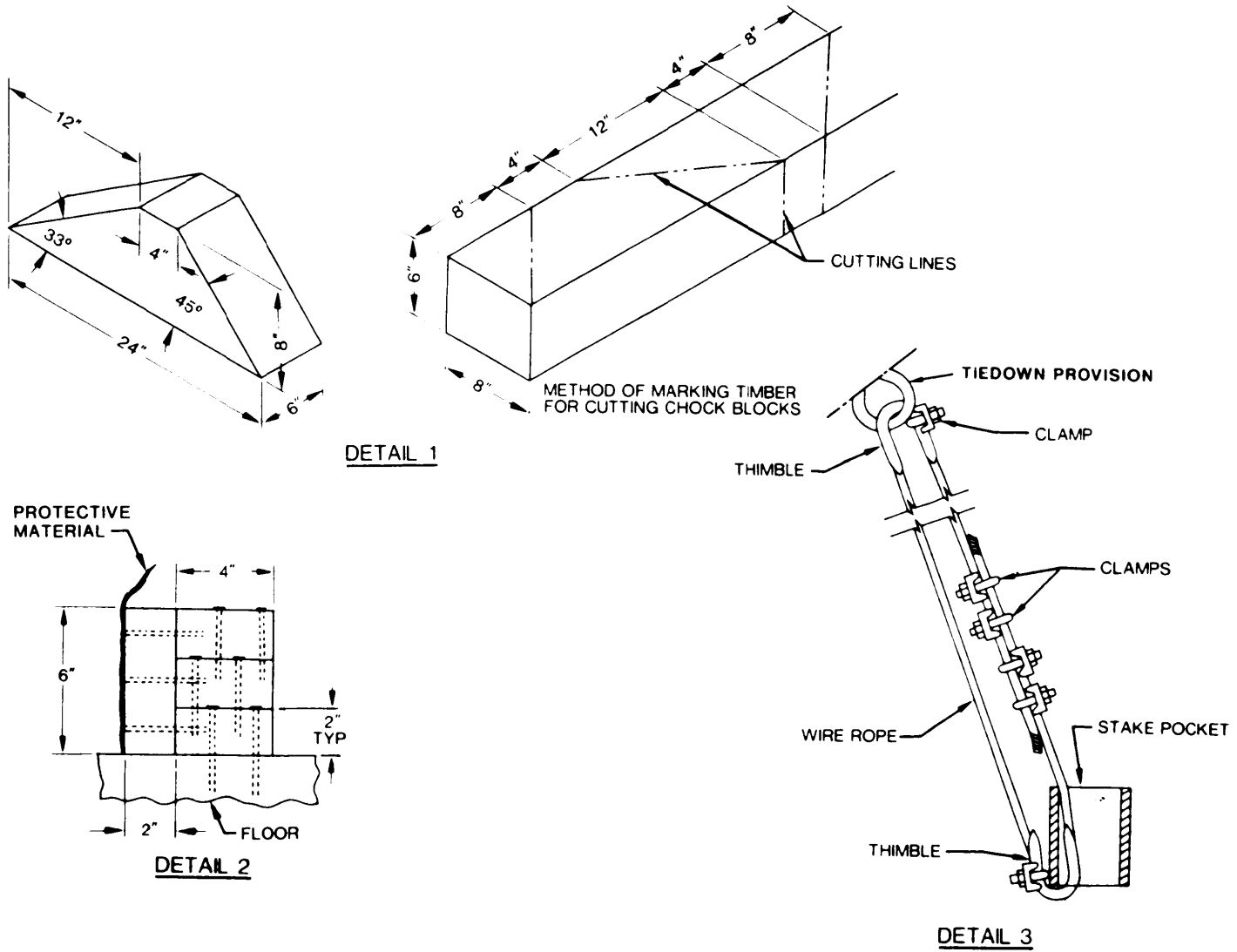

Figure 7-3. Typical blocking and tiedown detail diagram.

**Table 7-1. Bill of Materials for Blocking and Tiedown of the SEE and HME on a CONUS General-Purpose Flatcar (Figs 7-1 and 7-2)**

| Item                | Description   | Approximate Quantity |
|---------------------|---|----------------------|
| Lumber              | Douglas-fir, or comparable, straight-grain, free from material defects; Fed Spec MM-L-751H:     |                      |
|                     | 2- x 4-inch   | 36 linear feet       |
|                     | 2- x 6-inch   | 12 linear feet       |
|                     | 2- x 12-inch  | 16 linear feet       |
|                     | 6- x 8-inch   | 16 linear feet       |
| Nails               | Common, steel; flathead; bright or cement-coated; Fed Spec FF-N-105B:                           |                      |
|                     | 12d   | 20                   |
|                     | 20d   | 58                   |
|                     | 30d   | 40                   |
|                     | 40d   | 40                   |
| Thimbles            | Standard, open-type: 1/2-inch   | 18                   |
| Clamps              | Wire rope, U-bolt clips, saddle, single-grip, steel, Crosby heavy-duty, or equal;               |                      |
|                     | Fed Spec FF-C-450: 1/2-inch   | 42                   |
|                     | 5/8-inch  | 18                   |
| Protective material | Waterproof paper, burlap, or other suitable material  | as required          |
| Wire rope           | 6 x 19, IWRC; improved plow steel; preformed regular lay; table X, Fed Spec RR-W-410C: 1/2-inch | 200 feet             |
| Cushioning material | Felt, Padding, Sheet  | 2 Each               |

**Table 7-2. Application of Materials for Blocking and Tiedown of the SEE and HME on a CONUS General-Purpose Flatcar (Figs 7-1 and 7-2)**

| Item | No. Required | Application   |
|------|--------------|---|
| A    |              | Brake wheel clearance. Minimum clearance required is 6 inches above, in back of, and on both sides of, and 4 inches underneath wheel.   |
| B    | 8            | Blocks (detail 1, fig 7-3). Each consists of one piece of 6- x 8- x 24-inch lumber, cut as shown in detail 1. Place one block with 45° side against the front and rear of each wheel, and nail heel of block with five 40d nails.   |
| C    | 4            | Side blocks. Each consists of one piece of 2- x 6- x 36-inch lumber and three pieces of 2- x 4- x 36-inch lumber (detail 2, fig 7-3). Nail one edge of the 2- x 6- x 36-inch piece to the bottom 2- x 4- x 36-inch piece with five 12d nails. Then, place against tire and cushioning material (item D) and nail to car floor through the 2- x 4- x 36-inch piece with four 20d nails. Nail the other two 2- x 4- x 36-inch pieces to the one below in the same manner. |
| D    | 1            | Protective material. Place bottom portion under item C. The top portion should extend 2 inches above item C (detail 2, fig 7-3).  |
| E    | 8            | Wire rope. Each to consist of one piece 1/2-inch wire rope, length as required (about 18 feet). Form a complete loop between tiedown provision and the appropriate stake pocket (detail 3, fig 7-3). Wire rope ends should overlap a minimum of 24 inches.  |
| F    | 42           | Clamps, 1/2-inch. Except for items H, J, K, and M, place four 1/2-inch clips on each 1/2-inch wire rope at the overlapped area, and space 3 inches apart, with a minimum of 6 inches from ends of cable. For items H, J, K, and M, place two 1/2-inch clips on each 1/2-inch wire rope at the overlap area, and space 3 inches apart, with a minimum of 6 inches from ends of cable. Tighten the nuts on the 1/2-inch clips to a torque of 65 foot-pounds.              |
| G    | 18           | Thimbles, 1/2-inch. Place one at the bottom of each stake pocket and at each tiedown provision.   |



**Table 7-2 - Continued**

| Item | No. Required | Application  |
|------|--------------|--|
| H    | 1            | Wire rope, 1/2-inch (about 20 feet). Run end through stake pocket, forming a loop. Secure with two 1/2-inch clips. Run opposite end through both tiedown provisions on front loader and through stake pocket, forming second loop. Secure with two 1/2-inch clips.   |
| I    | 2            | <i>Shoring.</i> Each consists of one piece of 2- x 6- x 72-inch lumber. Raise front bucket and place one piece of lumber longitudinal, about 6 inches from each side of bucket. Nail each piece of lumber to railcar floor with five 20d nails. Lower bucket on top of blocking.                           |
| J    | 1            | <i>Wire rope, 1/2-inch (about 10 feet).</i> Run through ROPS and over backhoe attachment, forming a loop. Secure with two 1/2-inch clamps. Wire rope around ROPS and backhoe attachment arm shall be taut but not tight.   |
| K    | 2            | Wire rope, 1/2-inch, about 10 and 15 feet long. For the right outrigger, run the 10-foot piece through the bucket tiedown provision and around the outrigger. With the wire rope taut but not tight, secure with two 1/2-inch clips. Using the 15-foot piece, repeat the procedure for the left outrigger. |
| L    | 18           | <i>Clips, 5/8-inch.</i> Place one clip on each thimble (item G) at each stake pocket and tiedown provision to secure wire rope and thimble together (detail 3, fig 7-3).   |
| M    | 1            | <i>Wire rope, 1/2-inch, about 15 feet long.</i> Run through ROPS and over entrenched attachment, forming a loop. Secure with two 1/2-inch clamps. Wire rope (safety cable) shall be taut (not tight).  |
| N    | 2            | <i>Cushioning material.</i> Wrap each hydraulic cylinder with felt padding and tie with rope.  |

**General Instructions**

1. Set handbrakes and wire or block them in place.
2. Place and wire-tie gearshift levers in the neutral position.
3. Use an applicable-sized come-along mechanical hoist, or equal tensioning device, to tension wire rope.
4. See General Rules 1, 2, 3, 4, 5, 7, 9, 11, 12, 13, 14, 15, 19, 19A, 19B, and 19C in Section 1 of the *Rules Governing the Loading of Commodities on Open-Top Cars and Trailers*, published by the Association of American Railroads. These rules provide applicable guidelines and are mandatory in application.
5. Properly tighten the wire rope clamp nuts by using a proper sized torque wrench. After the nuts have been initially tightened, strike the "U" side of each clamp several times with a hammer to ensure proper seating into the dead end line, repeatedly and alternately tightening each clip nut to acquire final torque.

**NOTE**

Use a staggered nailing pattern to nail lumber or laminated lumber to the floor or a railcar. Adjust the nailing pattern for an upper piece of lumber, as required, so that a nail for that piece is not driven into or immediately adjacent to a nail in the lower piece of lumber.

**Table 7-3. Application of Chain Tiedowns for Securing the HMMH on HTTX or Similar Type of Flatcars (Figs 7-4 and 7-5)**

| Item | No. Required | Application  |
|------|--------------|--|
| A    |              | <i>Brake wheel clearance.</i> Minimum clearance required is 6 inches above, in back of, and on both sides of, and 4 inches underneath wheel.   |
| B    | 8            | Tiedown chains (furnished with railcar), 1/2-inch diameter alloy steel chain, extra strength, proof-tested to at least 27,000 pounds for vehicles over 25,000 pounds.  |
| C    | 1            | Wire rope (safety cable), 1/2-inch (about 10 feet). Run around both forklift tines and through both front lifting provisions, forming a loop. Secure with two 1/2-inch clamps. Wire rope shall be taut but not tight.  |
| D    | 2            | <i>Wire rope (safety cable).</i> Run one piece of 1/2-inch wire rope (safety cable about 16 feet long) around top of crane arm and through left center tiedown provision on chassis, forming a loop. Secure with two 1/2-inch clamps. Wire rope (safety cable) shall be taut but not tight. Repeat same procedure for right side, except loop wire rope (safety cable) through right tiedown provision on chassis. |

Table 7-3 – Continued

| Item | No. Required | Application   |
|------|--------------|---|
| E    | 1            | Wire rope (safety cable), 1/2-inch (about 18 feet). Run wire rope (safety cable) around left and right outriggers on rear crane implement, forming a loop. Secure with two 1/2-inch clamps. Wire rope (safety cable) shall be taut but not tight. |
| F    | 3            | <i>Clamps, 1/2-inch.</i> Place two on wire rope at the overlap area, and space 3 inches apart, with a minimum of 6 inches from ends of cable, and tighten.  |
| G    | 2            | <i>Blocking.</i> Each to consist of one piece, 2- x 6- x 48-inch lumber. Raise front forklift tines and place one piece laterally across both rub rails and lower tines on top of blocking and secure blocking to tines with wire.                |

### General Instructions

1. Shippers should specify cars equipped with tiedown devices in the quantity shown in table 7-3 when ordering specialized railway equipment. When carriers furnish cars without the requested tiedown equipment (chains and tensioning devices), chains and turnbuckles of appropriate size and strength will be used for tiedown of vehicles. Load binders are not to be used in place of turnbuckles to tension tiedown chains.
2. The HMMHs must face in the same direction and be uniformly spaced along the length of the car to allow sufficient space at each end of the car and between the HMMHs for tiedown. Apply tiedowns parallel to each other at the same end of the HMMH and from the HMMH tiedown point to the car tiedown point. The angle of the tiedown should be as close to 45° as possible.
3. Handbrakes are to be set and wired or blocked in place.
4. Gearshift levers must be placed and wire tied in the neutral position.
5. Open hooks must be secured with wire over opening to prevent the hook from becoming disengaged from the chain link to which it is attached.
6. Turnbuckles used to tighten chains must be wired or locked to prevent them from turning during transit unless turnbuckles are equipped with self-locking devices.
7. General rules 1, 2, 3, 4, 5, 7, 9, 11, 12, 13, 14, 15, 19, 19A, 19B, and 19C in Section 1 of Rules Governing the Loading of Commodities on Open-Top Cars and Trailers, published by the Association of American Railroads, provide further details and are mandatory in application.

## Section III. TRANSPORT ON FOREIGN RAILWAYS

### 7-7. General

The transportability guidance contained in this section applies when the SEE, HME, and HMMH is transported on foreign railways. Consideration is given to single and multiple SEE and variant movements on the type of rail cars normally used to move this type of equipment. The SEE and variants on flatcars are within the Gabarit International De Chargement (GIC) limits and can move unrestricted in Canada, Mexico, and Europe. Because of the various designation systems and clearances used by different countries, evaluation of transport capability must be on an individual basis.

### 7-8. Transport on Foreign-Service Flatcars

The SEE, HME, and HMMH can be transported on most foreign-service flatcars. The tractors should be transported in their reduced configurations. They can be moved, without restrictions, on standard flatcars throughout Europe. Materials required for blocking and tiedown on foreign-service flatcars are essentially the same as those used for rail transport within CONUS. Detailed guidance is contained in the 4th Transportation Command Pamphlet 55-2, *Tiedown Guide for Rail Movements*. This pamphlet can be obtained from the 4th Transportation Command, Oberursel, Germany,

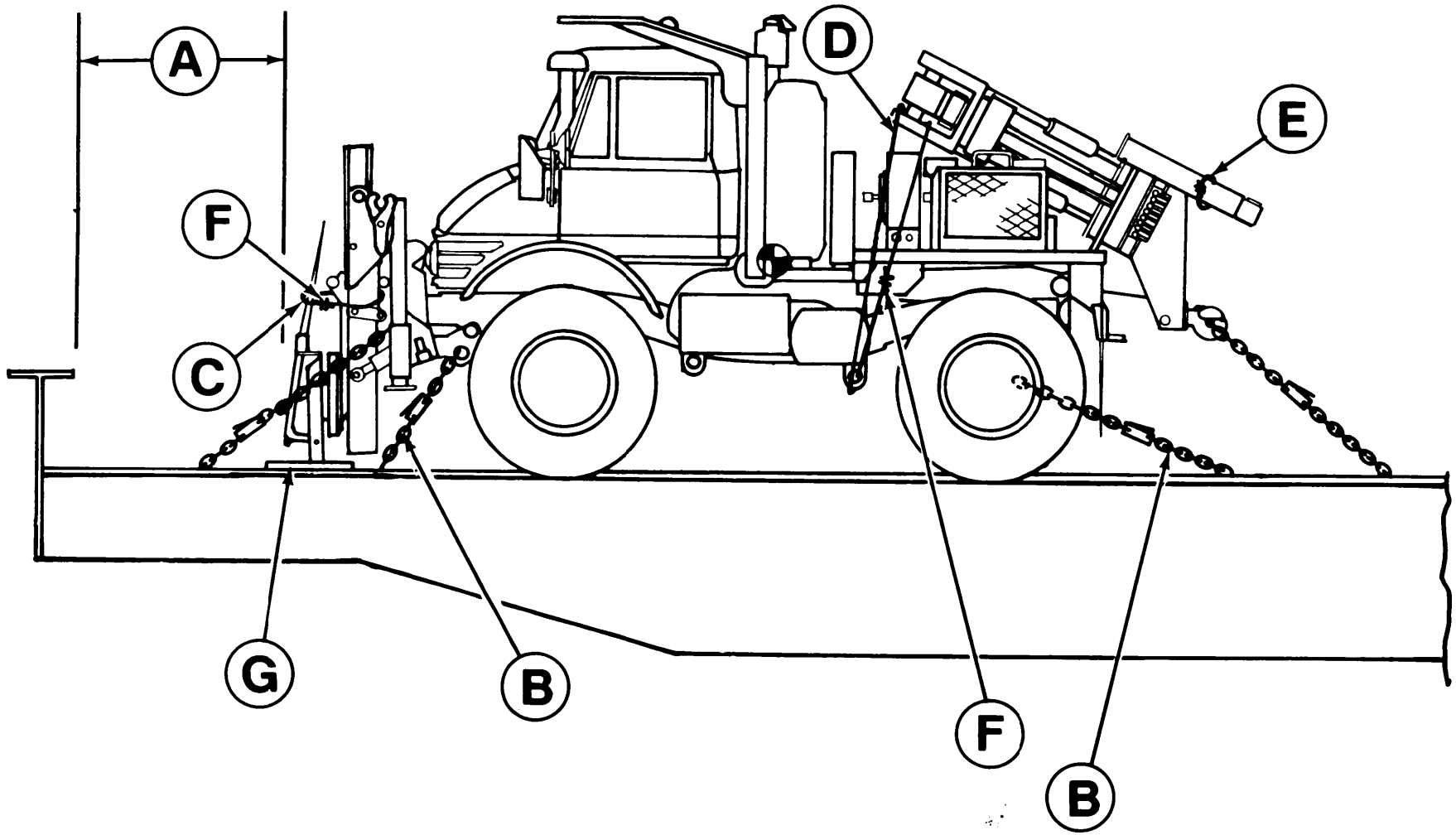

Figure 7-4. Typical tiedown for the SEE and variants on a CONUS conventional wood-deck, chain-tiedown flatcar (side view).

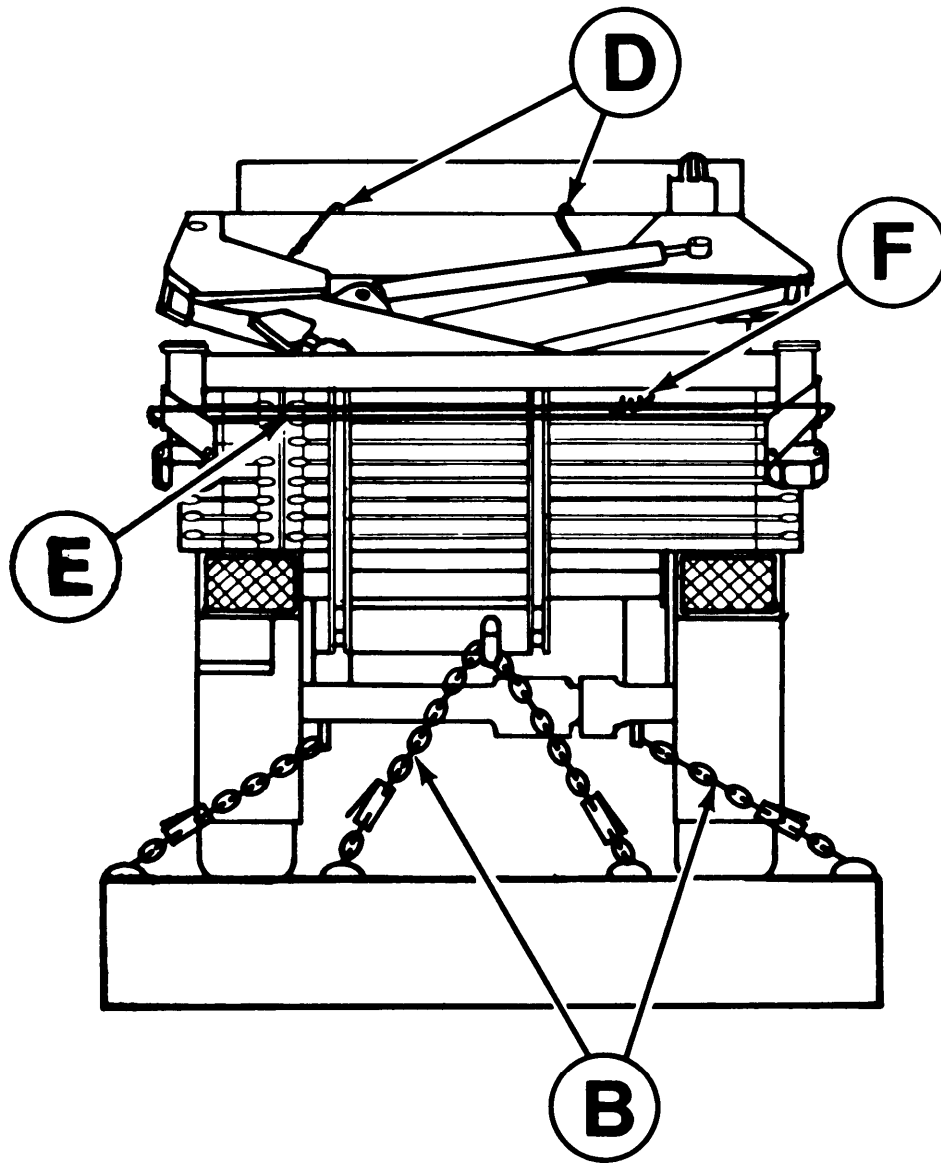

Figure 7-5. Typical tiedown for the SEE and variants on a CONUS conventional wood-deck, chain-tiedown flatcar (rear view).

## APPENDIX A

### CONVERSION TABLES

---

#### 1. Common Metric Abbreviations

m = meter  
dm = decimeter  
cm = centimeter  
mm = millimeter

kg = kilogram  
km = kilometer  
t = metric tons

#### 2. Linear Measure

1 mi = 1,609.35 m  
1 yd = 0.9144 m  
1 ft = 0.3048 m  
1 in. = 0.0254 m  
1 m = 10 dm = 100 cm = 1,000 mm

1 km = 0.6214 mi  
1 m = 1.0936 yd  
1 m = 3.2808 ft  
1 m = 39.3700 in.

#### 3. Surface Measure

1 sq yd = 0.8361 sq m  
1 sq ft = 0.0929 sq m  
1 sq in. = 0.00065 sq m

1 sq m = 1.196 sq yd  
1 sq m = 10.764 sq ft  
1 sq m = 1,550 sq in.

#### 4. Cubic Measure

1 cu yd = 0.76455 cu m  
1 cu ft = 0.02831 cu m  
1 cu in. = 0.000016 cu m

1 cu m = 1.31 cu yd  
1 cu m = 35.30 cu ft  
1 cu m = 61,023 cu in.

#### 5. Weight

1 STON = 907.185 kg  
1 lb = 0.45359 kg  
1 kg = 2.2046 lb

1 MT = 1,000 kg  
1 MT = 2,204.62 lb

6. The following simplified conversion factors are accurate to within 2 percent for quick computations:

*a. Inches to centimeters.* Multiply in. by 10 and divide by 4.

*b. Yards to meters.* Multiply yd by 9 and divide by 10.

*c. Miles to kilometers.* Multiply mi by 8 and divide by 5.

*d. Pounds to kilograms.* Multiply lb by 5 and divide by 11.

Paragraph 7-37, FM 55-15 and paragraph 2-15, TM 55-450-15 contain additional detailed conversion factors.

7. The following conversions are provided for guidance when procuring lumber, wire rope, or wire in areas that use the metric system. Lumber sizes are rounded off to nearest 1/2 cm.

*a. Lumber.*

(1) 2-in. x 4-in. x desired length = 5-cm x 10-cm x desired length.

(2) 1-in. x 6-in. x desired length = 2.5-cm x 15-cm x desired length.

(3) 6-in. x 8-in. x desired length = 15-cm x 20-cm x desired length.

(4) 1-in. x 12-in. x desired length = 2.5-cm x 30-cm x desired length (length normally expressed in ft or m).

*b. Wire rope.*

(1) 3/8-in. dia = 9.5-mm dia

(2) 1/2-in. dia = 12.7-mm dia

(3) 5/8-in. dia = 15.8-mm dia

(4) 3/4-in. dia = 19.0-mm dia

(5) 7/8-in. dia = 22.2-mm dia

(6) 1-in. dia = 25.4-mm dia

(7) 1-1/4-in. dia = 31.7-mm dia

(8) 1-1/2-in. dia = 38.1-mm dia

Round off to next higher whole mm of available wire rope sizes.

*c. Wire.* No. 8 gauge annealed (11/64-in. dia) = 4.37-mm dia. Round off as in b above.

## APPENDIX B REFERENCES

---

### 1. Army Regulations (AR)

|        |  |
|--------|--|
| 55-29  | Military Convoy Operations in CONUS  |
| 55-80  | Highways for National Defense  |
| 55-162 | Permits for Oversize, Overweight, or Other Special Military Move-<br>ments on Public Highways in the United States |
| 55-355 | Military Traffic Management Regulation   |
| 70-44  | DOD Engineering for Transportability   |
| 70-47  | Engineering for Transportability   |
| 385-40 | Accident Report and Records  |
| 746-1  | Packaging of Army Materiel for Shipment and Storage  |

### 2. Field Manuals (FM)

|       |  |
|-------|--|
| 55-9  | Unit Air Movement Plan                     |
| 55-15 | Transportation Reference Data              |
| 55-17 | Terminal Operations Coordinator's Handbook |

### 3. Supply Bulletins (SB)

|        |  |
|--------|--|
| 700-20 | Army Adopted/Other Items Selected for Authorized/List of Reportable<br>Items |
|--------|--|

### 4. Technical Bulletins (TB)

|         |  |
|---------|--|
| 55-46-1 | Standard Characteristics (Dimensions, Weight, and Cube) for Trans-<br>portability of Military Vehicles and Other Outsize/Overweight<br>Equipment |
|---------|--|

### 5. Technical Manuals

|                   |  |
|-------------------|--|
| 38-236 (AFP 71-8) | Preparation of Freight for Air Shipment  |
| 55-500            | Marine Equipment Characteristics and Data  |
| 55-600            | Transportation Services at Continental United States (CONUS) Instal-<br>lations  |
| 55-601            | Railcar Loading Procedures   |
| 55-2200-001-12    | Transportability Guidance:<br>Application of Blocking, Bracing, and Tiedown Materials for Rail<br>Transportation.<br>Koehing Commercial Parts Manual<br>Koehing Commercial Maintenance with Supplemental Operator<br>Maintenance and Repair and Instruction Manual |

### 6. Technical Orders (TO)

|           |  |
|-----------|--|
| 1-1B-40   | Handbook of Weight and Balance Data              |
| 1C-5A-9   | Loading Instructions, USAF-Series C-5A Airplane  |
| 1C-130-9  | Loading Instructions, USAF-Series C-130 Airplane |
| 1C-141B-9 | Loading Instructions, USAF-Series C-141 Airplane |

### 7. Other Publications and Source of Procurement

*a. Code of Federal Regulations.* Title 49 — Transportation, Parts 170-179.

Available from:

Superintendent of Documents  
US Government Printing Office  
Washington, DC 20402

**TM 55-2420-224-14**

*b. Association of American Railroads, Rules Governing the Loading of Commodities on Open-Top Cars and Trailers.*

Section No. 1 – General Rules

Section No. 6 – Rules Governing the Loading of Department of Defense

Material on Open-Top Cars

Available from: Association of American Railroads

50 F Street NW

Washington, DC 20001

*c. American Trucking Associations, Inc.*

2200 Mill Road

Alexandria, VA 22314-4654

**TM 55-2420-224-14**

By Order of the Secretary of the Army:

Official:

WILLIAM J. MEEHAN II  
*Brigadier General, United States Army*  
*The Adjutant General*

CARL E. VUONO  
*General, United States Army*  
*Chief of Staff*

**DISTRIBUTION:**

To be distributed in accordance with DA Form 12-25A, (block 2627, 2628, 2629) Operator, Unit, and Direct and General Support maintenance requirement for Tractor, Wheeled, Small Emplacement Excavator (SEE) R048, (2420-01-160-2754)



RECOMMENDED CHANGES TO EQUIPMENT TECHNICAL PUBLICATIONS



THEN...JOT DOWN THE DOPE ABOUT IT ON THIS FORM. CAREFULLY TEAR IT OUT, FOLD IT AND DROP IT IN THE MAIL.

SOMETHING WRONG WITH PUBLICATION

FROM: (PRINT YOUR UNIT'S COMPLETE ADDRESS)

DATE SENT

PUBLICATION NUMBER

PUBLICATION DATE

PUBLICATION TITLE

BE EXACT PIN-POINT WHERE IT IS

PAGE NO.

PARA-GRAPH

FIGURE NO.

TABLE NO.

IN THIS SPACE, TELL WHAT IS WRONG AND WHAT SHOULD BE DONE ABOUT IT.

TEAR ALONG PERFORATED LINE

PRINTED NAME, GRADE OR TITLE AND TELEPHONE NUMBER

SIGN HERE

# THE METRIC SYSTEM AND EQUIVALENTS

## WEIGHT MEASURE

1 Centimeter = 10 Millimeters = 0.01 Meters = 0.3937 Inches  
 1 Meter = 100 Centimeters = 1000 Millimeters = 39.37 Inches  
 1 Kilometer = 1000 Meters = 0.621 Miles

## WEIGHTS

1 Gram = 0.001 Kilograms = 1000 Milligrams = 0.035 Ounces  
 1 Kilogram = 1000 Grams = 2.2 lb.  
 1 Metric Ton = 1000 Kilograms = 1 Megagram = 1.1 Short Tons

## LIQUID MEASURE

1 Milliliter = 0.001 Liters = 0.0338 Fluid Ounces  
 1 Liter = 1000 Milliliters = 33.82 Fluid Ounces

## SQUARE MEASURE

1 Sq. Centimeter = 100 Sq. Millimeters = 0.155 Sq. Inches  
 1 Sq. Meter = 10,000 Sq. Centimeters = 10.76 Sq. Feet  
 1 Sq. Kilometer = 1,000,000 Sq. Meters = 0.386 Sq. Miles

## CUBIC MEASURE

1 Cu. Centimeter = 1000 Cu. Millimeters = 0.06 Cu. Inches  
 1 Cu. Meter = 1,000,000 Cu. Centimeters = 35.31 Cu. Feet

## TEMPERATURE

$5/9(^{\circ}\text{F} - 32) = ^{\circ}\text{C}$   
 212° Fahrenheit is equivalent to 100° Celsius  
 90° Fahrenheit is equivalent to 32.2° Celsius  
 32° Fahrenheit is equivalent to 0° Celsius  
 $9/5^{\circ}\text{C} + 32 = ^{\circ}\text{F}$

## APPROXIMATE CONVERSION FACTORS

| TO CHANGE              | TO                   | MULTIPLY BY |
|------------------------|----------------------|-------------|
| Inches                 | Centimeters          | 2.540       |
| Feet                   | Meters               | 0.305       |
| Yards                  | Meters               | 0.914       |
| Miles                  | Kilometers           | 1.609       |
| Square Inches          | Square Centimeters   | 6.451       |
| Square Feet            | Square Meters        | 0.093       |
| Square Yards           | Square Meters        | 0.836       |
| Square Miles           | Square Kilometers    | 2.590       |
| Acres                  | Square Hectometers   | 0.405       |
| Cubic Feet             | Cubic Meters         | 0.028       |
| Cubic Yards            | Cubic Meters         | 0.765       |
| Fluid Ounces           | Milliliters          | 29.573      |
| its                    | Liters               | 0.473       |
| arts                   | Liters               | 0.946       |
| allons                 | Liters               | 3.785       |
| Ounces                 | Grams                | 28.349      |
| Pounds                 | Kilograms            | 0.454       |
| Short Tons             | Metric Tons          | 0.907       |
| Pound-Feet             | Newton-Meters        | 1.356       |
| Pounds per Square Inch | Kilopascals          | 6.895       |
| Miles per Gallon       | Kilometers per Liter | 0.425       |
| Miles per Hour         | Kilometers per Hour  | 1.609       |

| TO CHANGE          | TO                     | MULTIPLY BY |
|--------------------|------------------------|-------------|
| Centimeters        | Inches                 | 0.394       |
| Meters             | Feet                   | 3.280       |
| Meters             | Yards                  | 1.094       |
| Kilometers         | Miles                  | 0.621       |
| Square Centimeters | Square Inches          | 0.155       |
| Square Meters      | Square Feet            | 10.764      |
| Square Meters      | Square Yards           | 1.196       |
| Square Kilometers  | Square Miles           | 0.386       |
| Square Hectometers | Acres                  | 2.471       |
| Cubic Meters       | Cubic Feet             | 35.315      |
| Cubic Meters       | Cubic Yards            | 1.308       |
| Milliliters        | Fluid Ounces           | 0.034       |
| Liters             | Pints                  | 2.113       |
| Liters             | Quarts                 | 1.057       |
| ers                | Gallons                | 0.264       |
| ms                 | Ounces                 | 0.035       |
| ograms             | Pounds                 | 2.205       |
| Metric Tons        | Short Tons             | 1.102       |
| Newton-Meters      | Pounds-Feet            | 0.738       |
| Kilopascals        | Pounds per Square Inch | 0.145       |
| ometers per Liter  | Miles per Gallon       | 2.354       |
| ometers per Hour   | Miles per Hour         | 0.621       |

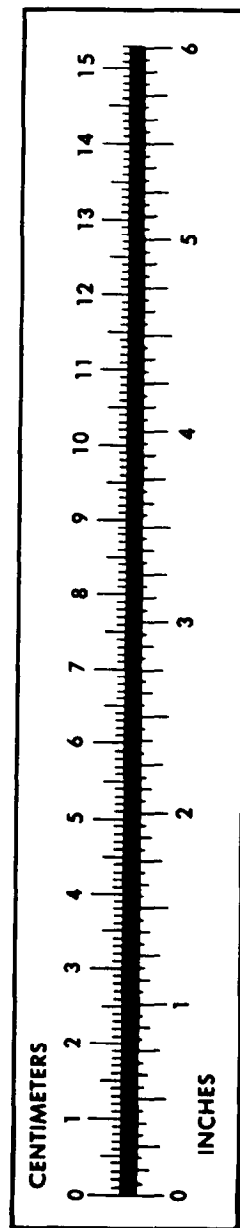

**PIN: 067392-000**